

CPU Instruction Set Details

A

This appendix provides a detailed description of the operation of each R4000 instruction in both 32- and 64-bit modes. The instructions are listed in alphabetical order.

Exceptions that may occur due to the execution of each instruction are listed after the description of each instruction. Descriptions of the immediate cause and manner of handling exceptions are omitted from the instruction descriptions in this appendix.

Figures at the end of this appendix list the bit encoding for the constant fields of each instruction, and the bit encoding for each individual instruction is included with that instruction.

A.1 Instruction Classes

CPU instructions are divided into the following classes:

- **Load** and **Store** instructions move data between memory and general registers. They are all I-type instructions, since the only addressing mode supported is *base register + 16-bit immediate offset*.
- **Computational** instructions perform arithmetic, logical and shift operations on values in registers. They occur in both R-type (both operands are registers) and I-type (one operand is a 16-bit immediate) formats.
- **Jump** and **Branch** instructions change the control flow of a program. Jumps are always made to absolute 26-bit word addresses (J-type format), or register addresses (R-type), for returns and dispatches. Branches have 16-bit offsets relative to the program counter (I-type). **Jump and Link** instructions save their return address in register 31.
- **Coprocessor** instructions perform operations in the coprocessors. Coprocessor loads and stores are I-type. Coprocessor computational instructions have coprocessor-dependent formats (see the FPU instructions in Appendix B). Coprocessor zero (CP0) instructions manipulate the memory management and exception handling facilities of the processor.
- **Special** instructions perform a variety of tasks, including movement of data between special and general registers, trap, and breakpoint. They are always R-type.

A.2 Instruction Formats

Every CPU instruction consists of a single word (32 bits) aligned on a word boundary and the major instruction formats are shown in Figure A-1.

I-Type (Immediate)

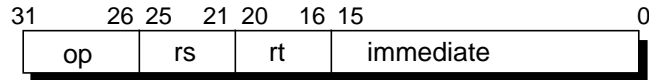

J-Type (Jump)

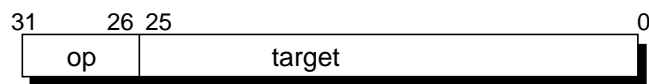

R-Type (Register)

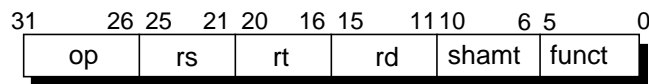

op	6-bit operation code
rs	5-bit source register specifier
rt	5-bit target (source/destination) or branch condition
immediate	16-bit immediate, branch displacement or address displacement
target	26-bit jump target address
rd	5-bit destination register specifier
shamt	5-bit shift amount
funct	6-bit function field

Figure A-1 CPU Instruction Formats

A.3 Instruction Notation Conventions

In this appendix, all variable subfields in an instruction format (such as *rs*, *rt*, *immediate*, etc.) are shown in lowercase names.

For the sake of clarity, we sometimes use an alias for a variable subfield in the formats of specific instructions. For example, we use *rs = base* in the format for load and store instructions. Such an alias is always lower case, since it refers to a variable subfield.

Figures with the actual bit encoding for all the mnemonics are located at the end of this Appendix, and the bit encoding also accompanies each instruction.

In the instruction descriptions that follow, the *Operation* section describes the operation performed by each instruction using a high-level language notation. The R4000 can operate as either a 32- or 64-bit microprocessor and the operation for both modes is included with the instruction description.

Special symbols used in the notation are described in Table A-1.

Table A-1 CPU Instruction Operation Notations

Symbol	Meaning
\leftarrow	Assignment.
\parallel	Bit string concatenation.
x^y	Replication of bit value x into a y -bit string. Note: x is always a single-bit value.
$x_{y:z}$	Selection of bits y through z of bit string x . Little-endian bit notation is always used. If y is less than z , this expression is an empty (zero length) bit string.
$+$	2's complement or floating-point addition.
$-$	2's complement or floating-point subtraction.
$*$	2's complement or floating-point multiplication.
div	2's complement integer division.
mod	2's complement modulo.
$/$	Floating-point division.
$<$	2's complement less than comparison.
and	Bit-wise logical AND.
or	Bit-wise logical OR.
xor	Bit-wise logical XOR.
nor	Bit-wise logical NOR.
GPR[x]	General-Register x . The content of GPR[0] is always zero. Attempts to alter the content of GPR[0] have no effect.
CPR[z,x]	Coprocessor unit z , general register x .
CCR[z,x]	Coprocessor unit z , control register x .
COC[z]	Coprocessor unit z condition signal.
BigEndianMem	Big-endian mode as configured at reset (0 \rightarrow Little, 1 \rightarrow Big). Specifies the endianness of the memory interface (see LoadMemory and StoreMemory), and the endianness of Kernel and Supervisor mode execution.
ReverseEndian	Signal to reverse the endianness of load and store instructions. This feature is available in User mode only, and is effected by setting the <i>RE</i> bit of the <i>Status</i> register. Thus, ReverseEndian may be computed as (SR ₂₅ and User mode).
BigEndianCPU	The endianness for load and store instructions (0 \rightarrow Little, 1 \rightarrow Big). In User mode, this endianness may be reversed by setting SR ₂₅ . Thus, BigEndianCPU may be computed as BigEndianMem XOR ReverseEndian.
LLbit	Bit of state to specify synchronization instructions. Set by <i>LL</i> , cleared by <i>ERET</i> and <i>Invalidate</i> and read by <i>SC</i> .
T+ i :	Indicates the time steps between operations. Each of the statements within a time step are defined to be executed in sequential order (as modified by conditional and loop constructs). Operations which are marked T+ i : are executed at instruction cycle i relative to the start of execution of the instruction. Thus, an instruction which starts at time j executes operations marked T+ i : at time $i + j$. The interpretation of the order of execution between two instructions or two operations which execute at the same time should be pessimistic; the order is not defined.

Instruction Notation Examples

The following examples illustrate the application of some of the instruction notation conventions:

Example #1:

$$\text{GPR}[rt] \leftarrow \text{immediate} \parallel 0^{16}$$

Sixteen zero bits are concatenated with an immediate value (typically 16 bits), and the 32-bit string (with the lower 16 bits set to zero) is assigned to General-Purpose Register *rt*.

Example #2:

$$(\text{immediate}_{15})^{16} \parallel \text{immediate}_{15\dots 0}$$

Bit 15 (the sign bit) of an immediate value is extended for 16 bit positions, and the result is concatenated with bits 15 through 0 of the immediate value to form a 32-bit sign extended value.

A.4 Load and Store Instructions

In the R4000 implementation, the instruction immediately following a load may use the loaded contents of the register. In such cases, the hardware *interlocks*, requiring additional real cycles, so scheduling load delay slots is still desirable, although not required for functional code.

Two special instructions are provided in the R4000 implementation of the MIPS ISA, Load Linked and Store Conditional. These instructions are used in carefully coded sequences to provide one of several synchronization primitives, including test-and-set, bit-level locks, semaphores, and sequencers/event counts.

In the load and store descriptions, the functions listed in Table A-2 are used to summarize the handling of virtual addresses and physical memory.

Table A-2 Load and Store Common Functions

Function	Meaning
AddressTranslation	Uses the TLB to find the physical address given the virtual address. The function fails and an exception is taken if the required translation is not present in the TLB.
LoadMemory	Uses the cache and main memory to find the contents of the word containing the specified physical address. The low-order two bits of the address and the <i>Access Type</i> field indicates which of each of the four bytes within the data word need to be returned. If the cache is enabled for this access, the entire word is returned and loaded into the cache.
StoreMemory	Uses the cache, write buffer, and main memory to store the word or part of word specified as data in the word containing the specified physical address. The low-order two bits of the address and the <i>Access Type</i> field indicates which of each of the four bytes within the data word should be stored.

As shown in Table A-3, the *Access Type* field indicates the size of the data item to be loaded or stored. Regardless of access type or byte-numbering order (endianness), the address specifies the byte which has the smallest byte address in the addressed field. For a big-endian machine, this is the leftmost byte and contains the sign for a 2's complement number; for a little-endian machine, this is the rightmost byte.

Table A-3 Access Type Specifications for Loads/Stores

Access Type Mnemonic	Value	Meaning
DOUBLEWORD	7	8 bytes (64 bits)
SEPTIBYTE	6	7 bytes (56 bits)
SEXTIBYTE	5	6 bytes (48 bits)
QUINTIBYTE	4	5 bytes (40 bits)
WORD	3	4 bytes (32 bits)
TRIPLEBYTE	2	3 bytes (24 bits)
HALFWORD	1	2 bytes (16 bits)
BYTE	0	1 byte (8 bits)

The bytes within the addressed doubleword which are used can be determined directly from the access type and the three low-order bits of the address.

A.5 Jump and Branch Instructions

All jump and branch instructions have an architectural delay of exactly one instruction. That is, the instruction immediately following a jump or branch (that is, occupying the delay slot) is always executed while the target instruction is being fetched from storage. A delay slot may not itself be occupied by a jump or branch instruction; however, this error is not detected and the results of such an operation are undefined.

If an exception or interrupt prevents the completion of a legal instruction during a delay slot, the hardware sets the *EPC* register to point at the jump or branch instruction that precedes it. When the code is restarted, both the jump or branch instructions and the instruction in the delay slot are reexecuted.

Because jump and branch instructions may be restarted after exceptions or interrupts, they must be restartable. Therefore, when a jump or branch instruction stores a return link value, register *31* (the register in which the link is stored) may not be used as a source register.

Since instructions must be word-aligned, a **Jump Register** or **Jump and Link Register** instruction must use a register whose two low-order bits are zero. If these low-order bits are not zero, an address exception will occur when the jump target instruction is subsequently fetched.

A.6 Coprocessor Instructions

Coprocessors are alternate execution units, which have register files separate from the CPU. The MIPS architecture provides four coprocessor units, or classes, and these coprocessors have two register spaces, each space containing thirty-two 32-bit registers.

- The first space, *coprocessor general* registers, may be directly loaded from memory and stored into memory, and their contents may be transferred between the coprocessor and processor.
- The second space, *coprocessor control* registers, may only have their contents transferred directly between the coprocessor and the processor. Coprocessor instructions may alter registers in either space.

A.7 System Control Coprocessor (CP0) Instructions

There are some special limitations imposed on operations involving CP0 that is incorporated within the CPU. Although load and store instructions to transfer data to/from coprocessors and to move control to/from coprocessor instructions are generally permitted by the MIPS architecture, CP0 is given a somewhat protected status since it has responsibility for exception handling and memory management. Therefore, the move to/from coprocessor instructions are the only valid mechanism for writing to and reading from the CP0 registers.

Several CP0 instructions are defined to directly read, write, and probe TLB entries and to modify the operating modes in preparation for returning to User mode or interrupt-enabled states.

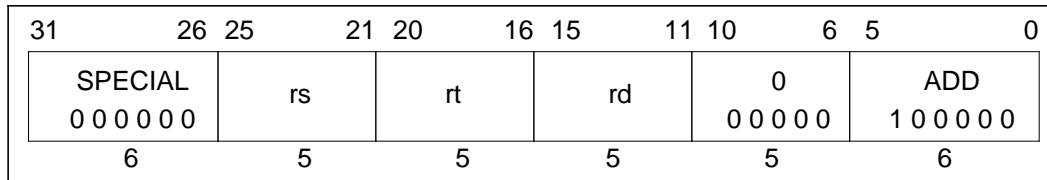
ADD**Add****ADD****Format:**

ADD rd, rs, rt

Description:

The contents of general register *rs* and the contents of general register *rt* are added to form the result. The result is placed into general register *rd*. In 64-bit mode, the operands must be valid sign-extended, 32-bit values.

An overflow exception occurs if the carries out of bits 30 and 31 differ (2's complement overflow). The destination register *rd* is not modified when an integer overflow exception occurs.

Operation:

32	T:	$GPR[rd] \leftarrow GPR[rs] + GPR[rt]$
64	T:	$temp \leftarrow GPR[rs] + GPR[rt]$ $GPR[rd] \leftarrow (temp_{31})^{32} temp_{31...0}$

Exceptions:

Integer overflow exception

ADDI Add Immediate ADDI

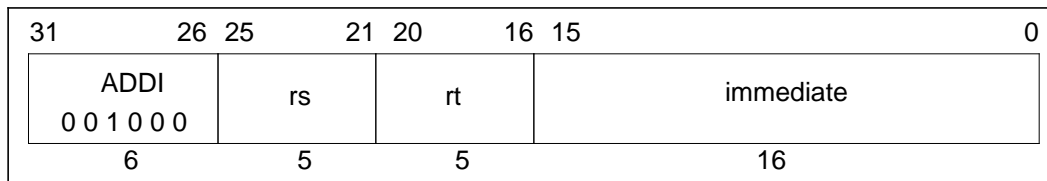
**Format:**ADDI *rt*, *rs*, *immediate***Description:**

The 16-bit *immediate* is sign-extended and added to the contents of general register *rs* to form the result. The result is placed into general register *rt*. In 64-bit mode, the operand must be valid sign-extended, 32-bit values.

An overflow exception occurs if carries out of bits 30 and 31 differ (2's complement overflow). The destination register *rt* is not modified when an integer overflow exception occurs.

Operation:

32	T: $GPR[rt] \leftarrow GPR[rs] + (immediate_{15})^{16} \parallel immediate_{15..0}$
64	T: $temp \leftarrow GPR[rs] + (immediate_{15})^{48} \parallel immediate_{15..0}$ $GPR[rt] \leftarrow (temp_{31})^{32} \parallel temp_{31..0}$

Exceptions:

Integer overflow exception

ADDIU Add Immediate Unsigned ADDIU

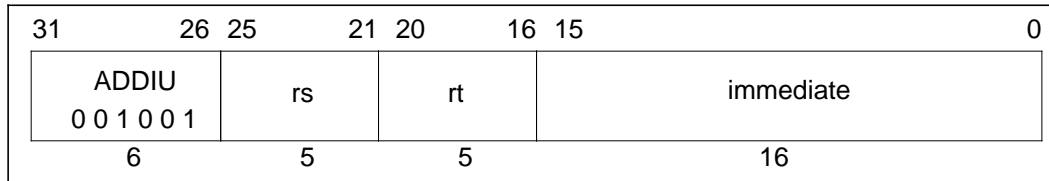
**Format:**

ADDIU rt, rs, immediate

Description:

The 16-bit *immediate* is sign-extended and added to the contents of general register *rs* to form the result. The result is placed into general register *rt*. No integer overflow exception occurs under any circumstances. In 64-bit mode, the operand must be valid sign-extended, 32-bit values.

The only difference between this instruction and the ADDI instruction is that ADDIU never causes an overflow exception.

Operation:

32	T: $GPR[rt] \leftarrow GPR[rs] + (immediate_{15})^{16} \parallel immediate_{15...0}$
64	T: $temp \leftarrow GPR[rs] + (immediate_{15})^{48} \parallel immediate_{15...0}$ $GPR[rt] \leftarrow (temp_{31})^{32} \parallel temp_{31...0}$

Exceptions:

None

ADDU Add Unsigned ADDU

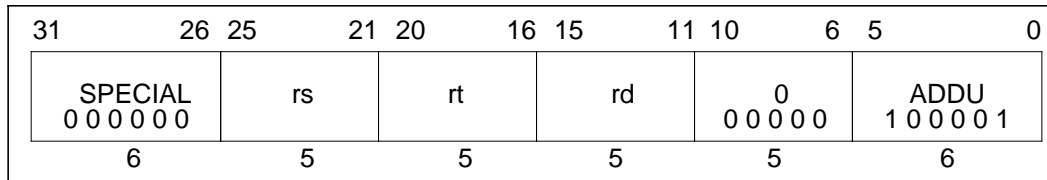
**Format:**

ADDU rd, rs, rt

Description:

The contents of general register *rs* and the contents of general register *rt* are added to form the result. The result is placed into general register *rd*. No overflow exception occurs under any circumstances. In 64-bit mode, the operands must be valid sign-extended, 32-bit values.

The only difference between this instruction and the ADD instruction is that ADDU never causes an overflow exception.

Operation:

32	T: $GPR[rd] \leftarrow GPR[rs] + GPR[rt]$
64	T: $temp \leftarrow GPR[rs] + GPR[rt]$ $GPR[rd] \leftarrow (temp_{31})^{32} temp_{31...0}$

Exceptions:

None

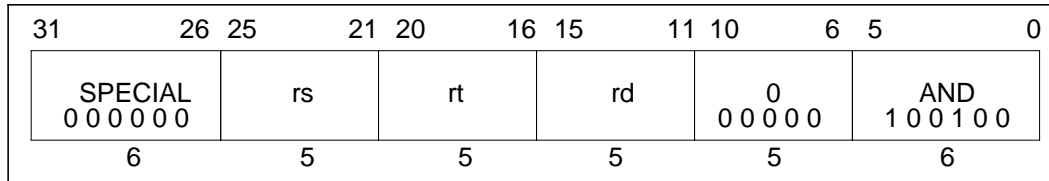
AND**And****AND****Format:**

AND rd, rs, rt

Description:

The contents of general register *rs* are combined with the contents of general register *rt* in a bit-wise logical AND operation. The result is placed into general register *rd*.

Operation:

32 T: GPR[rd] ← GPR[rs] and GPR[rt]

64 T: GPR[rd] ← GPR[rs] and GPR[rt]

Exceptions:

None

ANDI And Immediate ANDI

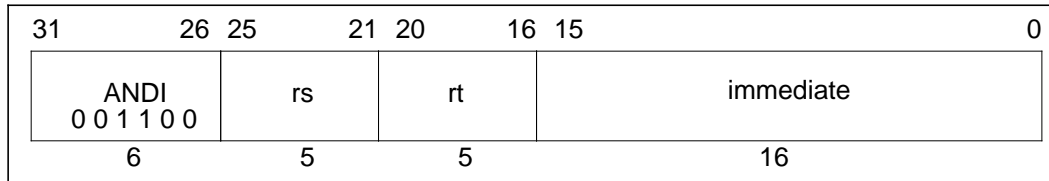
**Format:**

ANDI rt, rs, immediate

Description:

The 16-bit *immediate* is zero-extended and combined with the contents of general register *rs* in a bit-wise logical AND operation. The result is placed into general register *rt*.

Operation:

32 T: $GPR[rt] \leftarrow 0^{16} \parallel (\text{immediate and } GPR[rs]_{15..0})$

64 T: $GPR[rt] \leftarrow 0^{48} \parallel (\text{immediate and } GPR[rs]_{15..0})$

Exceptions:

None

BCzF Branch On Coprocessor z False BCzF

31	26 25	21 20	16 15	0
COPz 0 1 0 0 x x*	BC 0 1 0 0 0	BCF 0 0 0 0 0	offset	
6	5	5	16	

Format:

BCzF offset

Description:

A branch target address is computed from the sum of the address of the instruction in the delay slot and the 16-bit *offset*, shifted left two bits and sign-extended. If coprocessor *z*'s condition signal (CpCond), as sampled during the previous instruction, is false, then the program branches to the target address with a delay of one instruction.

Because the condition line is sampled during the previous instruction, there must be at least one instruction between this instruction and a coprocessor instruction that changes the condition line.

Operation:

32	T-1: condition \leftarrow not COC[z] T: target \leftarrow (offset ₁₅) ¹⁴ offset 0 ² T+1: if condition then PC \leftarrow PC + target endif
64	T-1: condition \leftarrow not COC[z] T: target \leftarrow (offset ₁₅) ⁴⁶ offset 0 ² T+1: if condition then PC \leftarrow PC + target endif

*See the table "Opcode Bit Encoding" on next page, or "CPU Instruction Opcode Bit Encoding" at the end of Appendix A.

BCzF

Branch On Coprocessor z False (continued)

BCzF

Exceptions:

Coprocessor unusable exception

Opcode Bit Encoding:

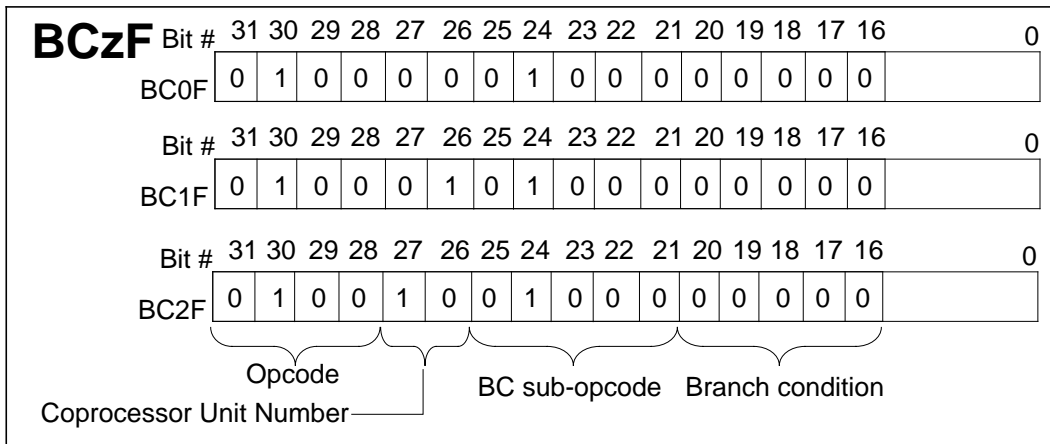

BCzFL Branch On Coprocessor z False Likely BCzFL

31	26 25	21 20	16 15	0
	COPz 0 1 0 0 x x*	BC 0 1 0 0 0	BCFL 0 0 0 1 0	offset
	6	5	5	16

Format:

BCzFL offset

Description:

A branch target address is computed from the sum of the address of the instruction in the delay slot and the 16-bit *offset*, shifted left two bits and sign-extended. If the contents of coprocessor *z*'s condition line, as sampled during the previous instruction, is false, the target address is branched to with a delay of one instruction.

If the conditional branch is not taken, the instruction in the branch delay slot is nullified.

Because the condition line is sampled during the previous instruction, there must be at least one instruction between this instruction and a coprocessor instruction that changes the condition line.

*See the table "Opcode Bit Encoding" on next page, or "CPU Instruction Opcode Bit Encoding" at the end of Appendix A.

BCzFL

Branch On Coprocessor z False Likely (continued)

BCzFL

Operation:

32	T-1: condition \leftarrow not COC[z] T: target \leftarrow (offset ₁₅) ¹⁴ offset 0 ² T+1: if condition then PC \leftarrow PC + target else NullifyCurrentInstruction endif
64	T-1: condition \leftarrow not COC[z] T: target \leftarrow (offset ₁₅) ⁴⁶ offset 0 ² T+1: if condition then PC \leftarrow PC + target else NullifyCurrentInstruction endif

Exceptions:

Coprocessor unusable exception

Opcode Bit Encoding:

BCzFL	Bit #	31	30	29	28	27	26	25	24	23	22	21	20	19	18	17	16	0
BC0FL		0	1	0	0	0	0	0	1	0	0	0	0	0	0	1	0	
	Bit #	31	30	29	28	27	26	25	24	23	22	21	20	19	18	17	16	0
BC1FL		0	1	0	0	0	1	0	1	0	0	0	0	0	0	1	0	
	Bit #	31	30	29	28	27	26	25	24	23	22	21	20	19	18	17	16	0
BC2FL		0	1	0	0	1	0	0	1	0	0	0	0	0	0	1	0	
		Opcode					BC sub-opcode					Branch condition						
	Coprocessor Unit Number																	

BCzT Branch On Coprocessor z True BCzT

31	26 25	21 20	16 15	0
COPz 0 1 0 0 x x*	BC 0 1 0 0 0	BCT 0 0 0 0 1	offset	
6	5	5	16	

Format:

BCzT offset

Description:

A branch target address is computed from the sum of the address of the instruction in the delay slot and the 16-bit *offset*, shifted left two bits and sign-extended. If the coprocessor *z*'s condition signal (CpCond) is true, then the program branches to the target address, with a delay of one instruction.

Because the condition line is sampled during the previous instruction, there must be at least one instruction between this instruction and a coprocessor instruction that changes the condition line.

Operation:

32	T-1: condition \leftarrow COC[z] T: target \leftarrow (offset ₁₅) ¹⁴ offset 0 ² T+1: if condition then PC \leftarrow PC + target endif
64	T-1: condition \leftarrow COC[z] T: target \leftarrow (offset ₁₅) ⁴⁶ offset 0 ² T+1: if condition then PC \leftarrow PC + target endif

*See the table "Opcode Bit Encoding" on next page, or "CPU Instruction Opcode Bit Encoding" at the end of Appendix A.

BCzT Branch On Coprocessor z True BCzT

(continued)

Exceptions:

Coprocessor unusable exception

Opcode Bit Encoding:

BCzT	Bit #	31	30	29	28	27	26	25	24	23	22	21	20	19	18	17	16	0
	BC0T	0	1	0	0	0	0	0	1	0	0	0	0	0	0	0	1	
	Bit #	31	30	29	28	27	26	25	24	23	22	21	20	19	18	17	16	0
	BC1T	0	1	0	0	0	1	0	1	0	0	0	0	0	0	0	1	
	Bit #	31	30	29	28	27	26	25	24	23	22	21	20	19	18	17	16	0
	BC2T	0	1	0	0	1	0	0	1	0	0	0	0	0	0	0	1	
	Coproprocessor Unit Number	{					{					{						
		Opcode					BC sub-opcode					Branch condition						

BCzTL Branch On Coprocessor z True Likely BCzTL

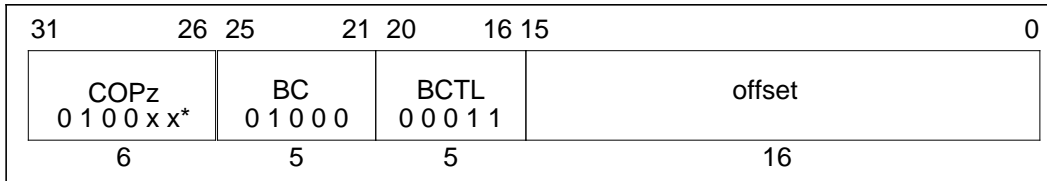
**Format:**

BCzTL offset

Description:

A branch target address is computed from the sum of the address of the instruction in the delay slot and the 16-bit *offset*, shifted left two bits and sign-extended. If the contents of coprocessor *z*'s condition line, as sampled during the previous instruction, is true, the target address is branched to with a delay of one instruction.

If the conditional branch is not taken, the instruction in the branch delay slot is nullified.

Because the condition line is sampled during the previous instruction, there must be at least one instruction between this instruction and a coprocessor instruction that changes the condition line.

Operation:

32	T-1: condition \leftarrow COC[z] T: target \leftarrow (offset ₁₅) ¹⁴ offset 0 ² T+1: if condition then else PC \leftarrow PC + target NullifyCurrentInstruction endif
64	T-1: condition \leftarrow COC[z] T: target \leftarrow (offset ₁₅) ⁴⁶ offset 0 ² T+1: if condition then PC \leftarrow PC + target else NullifyCurrentInstruction endif

*See the table "Opcode Bit Encoding" on next page, or "CPU Instruction Opcode Bit Encoding" at the end of Appendix A.

BCzTL

Branch On Coprocessor z True Likely (continued)

BCzTL

Exceptions:

Coprocessor unusable exception

Opcode Bit Encoding:

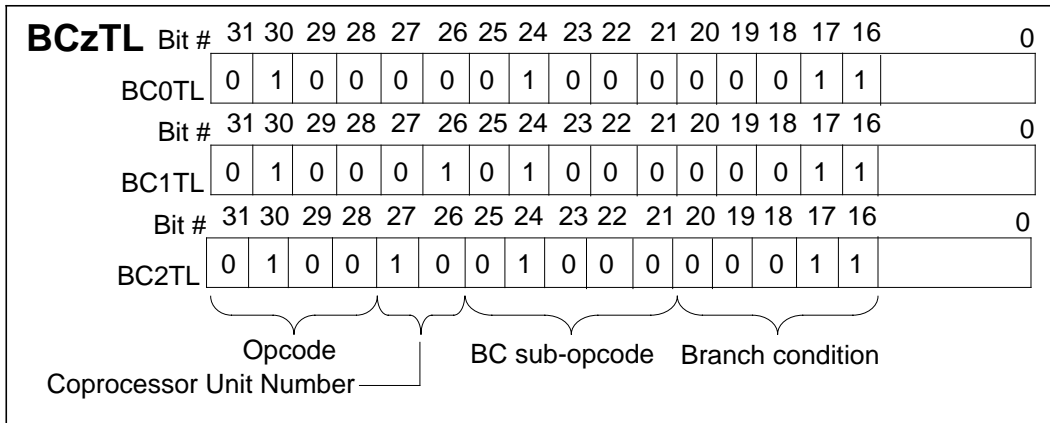

BEQ Branch On Equal BEQ

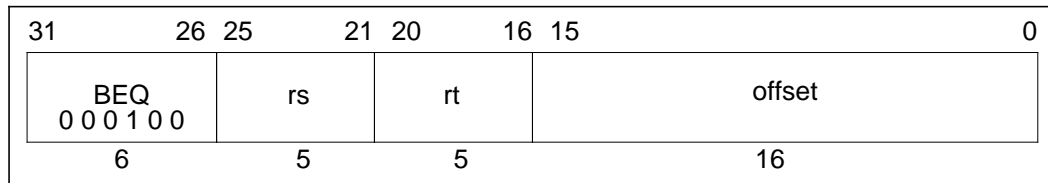
**Format:**

BEQ rs, rt, offset

Description:

A branch target address is computed from the sum of the address of the instruction in the delay slot and the 16-bit *offset*, shifted left two bits and sign-extended. The contents of general register *rs* and the contents of general register *rt* are compared. If the two registers are equal, then the program branches to the target address, with a delay of one instruction.

Operation:

32	T: target \leftarrow (offset ₁₅) ¹⁴ offset 0 ² condition \leftarrow (GPR[rs] = GPR[rt]) T+1: if condition then PC \leftarrow PC + target endif
64	T: target \leftarrow (offset ₁₅) ⁴⁶ offset 0 ² condition \leftarrow (GPR[rs] = GPR[rt]) T+1: if condition then PC \leftarrow PC + target endif

Exceptions:

None

BEQL Branch On Equal Likely BEQL

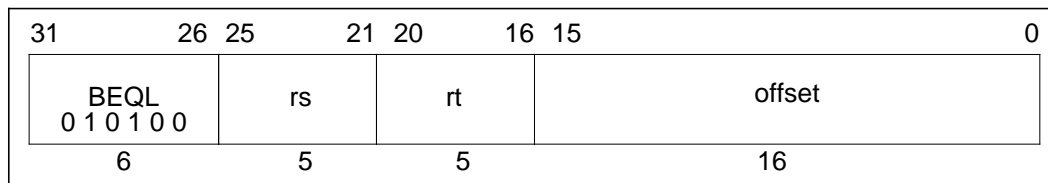
**Format:**

BEQL rs, rt, offset

Description:

A branch target address is computed from the sum of the address of the instruction in the delay slot and the 16-bit offset, shifted left two bits and sign-extended. The contents of general register *rs* and the contents of general register *rt* are compared. If the two registers are equal, the target address is branched to, with a delay of one instruction. If the conditional branch is not taken, the instruction in the branch delay slot is nullified.

Operation:

32	T: target \leftarrow (offset ₁₅) ¹⁴ offset 0 ² condition \leftarrow (GPR[rs] = GPR[rt]) T+1: if condition then else PC \leftarrow PC + target NullifyCurrentInstruction endif
64	T: target \leftarrow (offset ₁₅) ⁴⁶ offset 0 ² condition \leftarrow (GPR[rs] = GPR[rt]) T+1: if condition then PC \leftarrow PC + target else NullifyCurrentInstruction endif

Exceptions:

None

BGEZ Branch On Greater Than Or Equal To Zero BGEZ

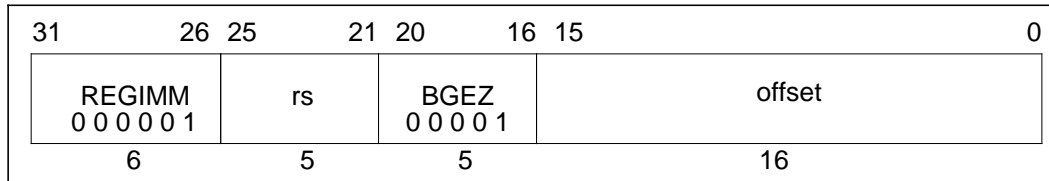
**Format:**

BGEZ rs, offset

Description:

A branch target address is computed from the sum of the address of the instruction in the delay slot and the 16-bit *offset*, shifted left two bits and sign-extended. If the contents of general register *rs* have the sign bit cleared, then the program branches to the target address, with a delay of one instruction.

Operation:

32	T: target \leftarrow (offset ₁₅) ¹⁴ offset 0 ² condition \leftarrow (GPR[rs] ₃₁ = 0) T+1: if condition then PC \leftarrow PC + target endif
64	T: target \leftarrow (offset ₁₅) ⁴⁶ offset 0 ² condition \leftarrow (GPR[rs] ₆₃ = 0) T+1: if condition then PC \leftarrow PC + target endif

Exceptions:

None

BGEZALL Branch On Greater Than Or Equal To Zero And Link Likely BGEZALL

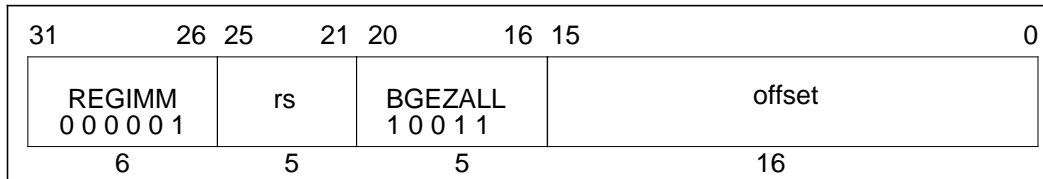
**Format:**

BGEZALL rs, offset

Description:

A branch target address is computed from the sum of the address of the instruction in the delay slot and the 16-bit *offset*, shifted left two bits and sign-extended. Unconditionally, the address of the instruction after the delay slot is placed in the link register, *r31*. If the contents of general register *rs* have the sign bit cleared, then the program branches to the target address, with a delay of one instruction. General register *rs* may not be general register *31*, because such an instruction is not restartable. An attempt to execute this instruction is not trapped, however. If the conditional branch is not taken, the instruction in the branch delay slot is nullified.

Operation:

32	T: target \leftarrow (offset ₁₅) ¹⁴ offset 0 ² condition \leftarrow (GPR[rs] ₃₁ = 0) GPR[31] \leftarrow PC + 8 T+1: if condition then PC \leftarrow PC + target else NullifyCurrentInstruction endif
64	T: target \leftarrow (offset ₁₅) ⁴⁶ offset 0 ² condition \leftarrow (GPR[rs] ₆₃ = 0) GPR[31] \leftarrow PC + 8 T+1: if condition then PC \leftarrow PC + target else NullifyCurrentInstruction endif

Exceptions:

None

BGEZL Branch On Greater Than Or Equal To Zero Likely BGEZL

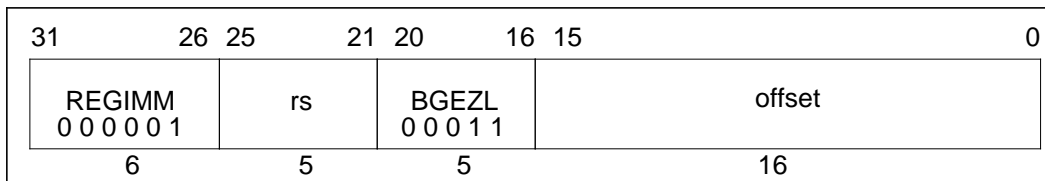
**Format:**

BGEZL rs, offset

Description:

A branch target address is computed from the sum of the address of the instruction in the delay slot and the 16-bit *offset*, shifted left two bits and sign-extended. If the contents of general register *rs* have the sign bit cleared, then the program branches to the target address, with a delay of one instruction. If the conditional branch is not taken, the instruction in the branch delay slot is nullified.

Operation:

32	T: target \leftarrow (offset ₁₅) ¹⁴ offset 0 ² condition \leftarrow (GPR[rs] ₃₁ = 0) T+1: if condition then PC \leftarrow PC + target else NullifyCurrentInstruction endif
64	T: target \leftarrow (offset ₁₅) ⁴⁶ offset 0 ² condition \leftarrow (GPR[rs] ₆₃ = 0) T+1: if condition then PC \leftarrow PC + target else NullifyCurrentInstruction endif

Exceptions:

None

BGTZ Branch On Greater Than Zero BGTZ

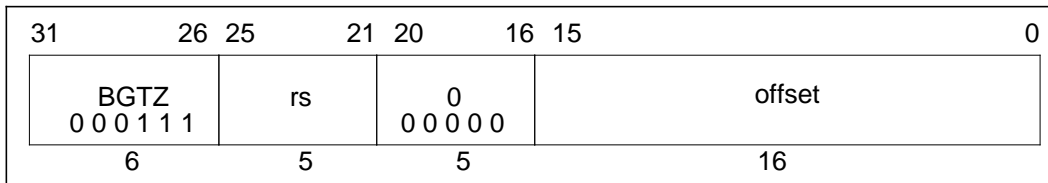
**Format:**

BGTZ rs, offset

Description:

A branch target address is computed from the sum of the address of the instruction in the delay slot and the 16-bit *offset*, shifted left two bits and sign-extended. The contents of general register *rs* are compared to zero. If the contents of general register *rs* have the sign bit cleared and are not equal to zero, then the program branches to the target address, with a delay of one instruction.

Operation:

32	T: $\text{target} \leftarrow (\text{offset}_{15})^{14} \parallel \text{offset} \parallel 0^2$ $\text{condition} \leftarrow (\text{GPR}[\text{rs}]_{31} = 0) \text{ and } (\text{GPR}[\text{rs}] \neq 0^{32})$ T+1: if condition then PC \leftarrow PC + target endif
64	T: $\text{target} \leftarrow (\text{offset}_{15})^{46} \parallel \text{offset} \parallel 0^2$ $\text{condition} \leftarrow (\text{GPR}[\text{rs}]_{63} = 0) \text{ and } (\text{GPR}[\text{rs}] \neq 0^{64})$ T+1: if condition then PC \leftarrow PC + target endif

Exceptions:

None

BGTZL Branch On Greater Than Zero Likely BGTZL

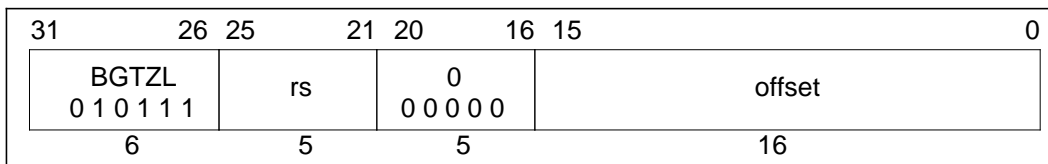
**Format:**

BGTZL rs, offset

Description:

A branch target address is computed from the sum of the address of the instruction in the delay slot and the 16-bit *offset*, shifted left two bits and sign-extended. The contents of general register *rs* are compared to zero. If the contents of general register *rs* have the sign bit cleared and are not equal to zero, then the program branches to the target address, with a delay of one instruction. If the conditional branch is not taken, the instruction in the branch delay slot is nullified.

Operation:

32	T: $\text{target} \leftarrow (\text{offset}_{15})^{14} \parallel \text{offset} \parallel 0^2$ $\text{condition} \leftarrow (\text{GPR}[\text{rs}]_{31} = 0) \text{ and } (\text{GPR}[\text{rs}] \neq 0^{32})$ T+1: if condition then PC \leftarrow PC + target else NullifyCurrentInstruction endif
64	T: $\text{target} \leftarrow (\text{offset}_{15})^{46} \parallel \text{offset} \parallel 0^2$ $\text{condition} \leftarrow (\text{GPR}[\text{rs}]_{63} = 0) \text{ and } (\text{GPR}[\text{rs}] \neq 0^{64})$ T+1: if condition then PC \leftarrow PC + target else NullifyCurrentInstruction endif

Exceptions:

None

BLEZ Branch on Less Than Or Equal To Zero BLEZ

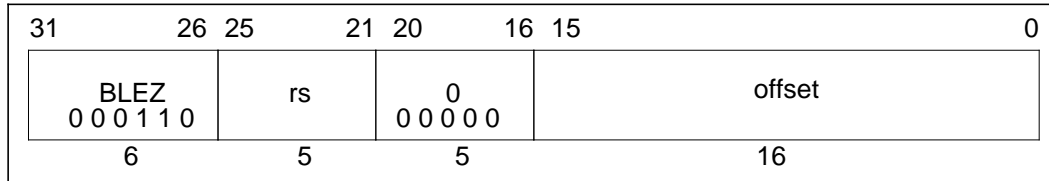
**Format:**

BLEZ rs, offset

Description:

A branch target address is computed from the sum of the address of the instruction in the delay slot and the 16-bit *offset*, shifted left two bits and sign-extended. The contents of general register *rs* are compared to zero. If the contents of general register *rs* have the sign bit set, or are equal to zero, then the program branches to the target address, with a delay of one instruction.

Operation:

32	T: target \leftarrow (offset ₁₅) ¹⁴ offset 0 ² condition \leftarrow (GPR[rs] ₃₁ = 1) or (GPR[rs] = 0 ³²) T+1: if condition then PC \leftarrow PC + target endif
64	T: target \leftarrow (offset ₁₅) ⁴⁶ offset 0 ² condition \leftarrow (GPR[rs] ₆₃ = 1) or (GPR[rs] = 0 ⁶⁴) T+1: if condition then PC \leftarrow PC + target endif

Exceptions:

None

BLEZL Branch on Less Than Or Equal To Zero Likely BLEZL

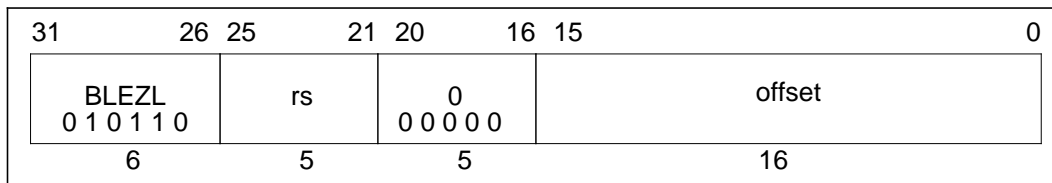
**Format:**

BLEZL rs, offset

Description:

A branch target address is computed from the sum of the address of the instruction in the delay slot and the 16-bit *offset*, shifted left two bits and sign-extended. The contents of general register *rs* is compared to zero. If the contents of general register *rs* have the sign bit set, or are equal to zero, then the program branches to the target address, with a delay of one instruction.

If the conditional branch is not taken, the instruction in the branch delay slot is nullified.

Operation:

32	T: target \leftarrow (offset ₁₅) ¹⁴ offset 0 ² condition \leftarrow (GPR[rs] ₃₁ = 1) or (GPR[rs] = 0 ³²)
	T+1: if condition then PC \leftarrow PC + target else NullifyCurrentInstruction endif
64	T: target \leftarrow (offset ₁₅) ⁴⁶ offset 0 ² condition \leftarrow (GPR[rs] ₆₃ = 1) or (GPR[rs] = 0 ⁶⁴)
	T+1: if condition then PC \leftarrow PC + target else NullifyCurrentInstruction endif

Exceptions:

None

BLTZ Branch On Less Than Zero BLTZ

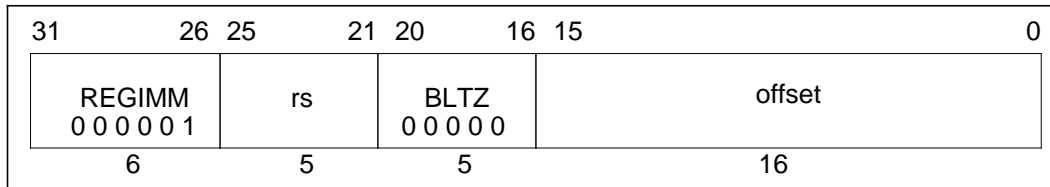
**Format:**

BLTZ rs, offset

Description:

A branch target address is computed from the sum of the address of the instruction in the delay slot and the 16-bit *offset*, shifted left two bits and sign-extended. If the contents of general register *rs* have the sign bit set, then the program branches to the target address, with a delay of one instruction.

Operation:

32	T: target \leftarrow (offset ₁₅) ¹⁴ offset 0 ² condition \leftarrow (GPR[rs] ₃₁ = 1) T+1: if condition then PC \leftarrow PC + target endif
64	T: target \leftarrow (offset ₁₅) ⁴⁶ offset 0 ² condition \leftarrow (GPR[rs] ₆₃ = 1) T+1: if condition then PC \leftarrow PC + target endif

Exceptions:

None

BLTZAL Branch On Less Than Zero And Link BLTZAL

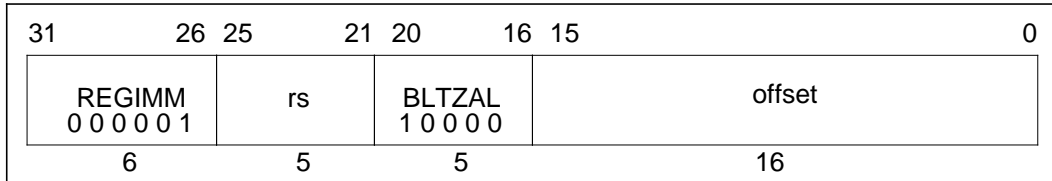
**Format:**

BLTZAL rs, offset

Description:

A branch target address is computed from the sum of the address of the instruction in the delay slot and the 16-bit *offset*, shifted left two bits and sign-extended. Unconditionally, the address of the instruction after the delay slot is placed in the link register, *r31*. If the contents of general register *rs* have the sign bit set, then the program branches to the target address, with a delay of one instruction.

General register *rs* may not be general register *31*, because such an instruction is not restartable. An attempt to execute this instruction with register *31* specified as *rs* is not trapped, however.

Operation:

32	T: $\text{target} \leftarrow (\text{offset}_{15})^{14} \parallel \text{offset} \parallel 0^2$ $\text{condition} \leftarrow (\text{GPR}[\text{rs}]_{31} = 1)$ $\text{GPR}[31] \leftarrow \text{PC} + 8$ T+1: if condition then $\text{PC} \leftarrow \text{PC} + \text{target}$ endif
64	T: $\text{target} \leftarrow (\text{offset}_{15})^{46} \parallel \text{offset} \parallel 0^2$ $\text{condition} \leftarrow (\text{GPR}[\text{rs}]_{63} = 1)$ $\text{GPR}[31] \leftarrow \text{PC} + 8$ T+1: if condition then $\text{PC} \leftarrow \text{PC} + \text{target}$ endif

Exceptions:

None

BLTZALL Branch On Less Than Zero And Link Likely BLTZALL

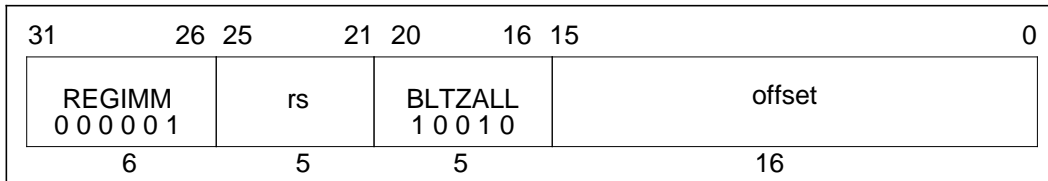
**Format:**

BLTZALL rs, offset

Description:

A branch target address is computed from the sum of the address of the instruction in the delay slot and the 16-bit *offset*, shifted left two bits and sign-extended. Unconditionally, the address of the instruction after the delay slot is placed in the link register, *r31*. If the contents of general register *rs* have the sign bit set, then the program branches to the target address, with a delay of one instruction.

General register *rs* may not be general register *31*, because such an instruction is not restartable. An attempt to execute this instruction with register *31* specified as *rs* is not trapped, however. If the conditional branch is not taken, the instruction in the branch delay slot is nullified.

Operation:

```

32  T:  target ← (offset15)14 || offset || 02
      condition ← (GPR[rs]31 = 1)
      GPR[31] ← PC + 8
      T+1: if condition then
            PC ← PC + target
            else NullifyCurrentInstruction
            endif
64  T:  target ← (offset15)46 || offset || 02
      condition ← (GPR[rs]63 = 1)
      GPR[31] ← PC + 8
      T+1: if condition then
            PC ← PC + target
            else NullifyCurrentInstruction
            endif

```

Exceptions:

None

BLTZL Branch On Less Than Zero Likely BLTZL

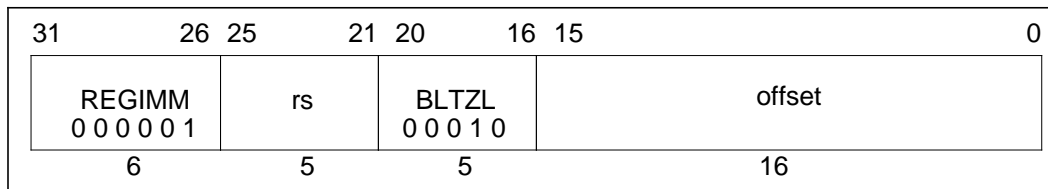
**Format:**

BLTZ rs, offset

Description:

A branch target address is computed from the sum of the address of the instruction in the delay slot and the 16-bit *offset*, shifted left two bits and sign-extended. If the contents of general register *rs* have the sign bit set, then the program branches to the target address, with a delay of one instruction. If the conditional branch is not taken, the instruction in the branch delay slot is nullified.

Operation:

32	T: target \leftarrow (offset ₁₅) ¹⁴ offset 0 ² condition \leftarrow (GPR[rs] ₃₁ = 1)
T+1: if condition then	PC \leftarrow PC + target
	else
	NullifyCurrentInstruction
	endif
64	T: target \leftarrow (offset ₁₅) ⁴⁶ offset 0 ² condition \leftarrow (GPR[rs] ₆₃ = 1)
T+1: if condition then	PC \leftarrow PC + target
	else
	NullifyCurrentInstruction
	endif

Exceptions:

None

BNE Branch On Not Equal BNE

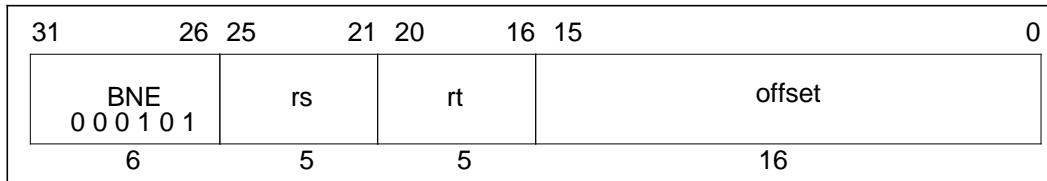
**Format:**

BNE rs, rt, offset

Description:

A branch target address is computed from the sum of the address of the instruction in the delay slot and the 16-bit *offset*, shifted left two bits and sign-extended. The contents of general register *rs* and the contents of general register *rt* are compared. If the two registers are not equal, then the program branches to the target address, with a delay of one instruction.

Operation:

32	T: target \leftarrow (offset ₁₅) ¹⁴ offset 0 ² condition \leftarrow (GPR[rs] \neq GPR[rt]) T+1: if condition then PC \leftarrow PC + target endif
64	T: target \leftarrow (offset ₁₅) ⁴⁶ offset 0 ² condition \leftarrow (GPR[rs] \neq GPR[rt]) T+1: if condition then PC \leftarrow PC + target endif

Exceptions:

None

BNEL Branch On Not Equal Likely BNEL

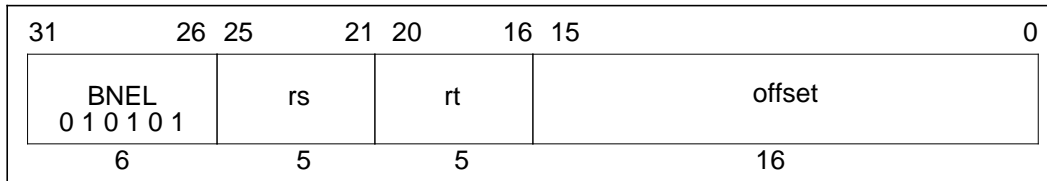
**Format:**

BNEL rs, rt, offset

Description:

A branch target address is computed from the sum of the address of the instruction in the delay slot and the 16-bit *offset*, shifted left two bits and sign-extended. The contents of general register *rs* and the contents of general register *rt* are compared. If the two registers are not equal, then the program branches to the target address, with a delay of one instruction.

If the conditional branch is not taken, the instruction in the branch delay slot is nullified.

Operation:

32	T: target \leftarrow (offset ₁₅) ¹⁴ offset 0 ² condition \leftarrow (GPR[rs] \neq GPR[rt]) T+1: if condition then PC \leftarrow PC + target else NullifyCurrentInstruction endif
64	T: target \leftarrow (offset ₁₅) ⁴⁶ offset 0 ² condition \leftarrow (GPR[rs] \neq GPR[rt]) T+1: if condition then PC \leftarrow PC + target else NullifyCurrentInstruction endif

Exceptions:

None

BREAK Breakpoint BREAK

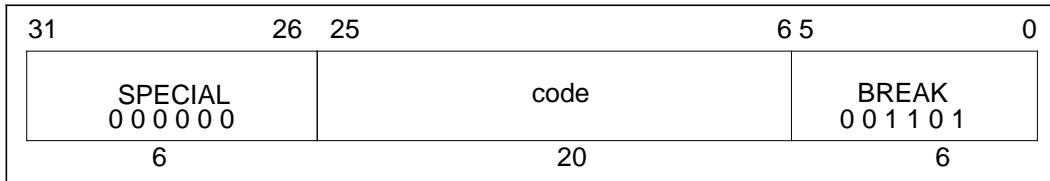
**Format:**

BREAK

Description:

A breakpoint trap occurs, immediately and unconditionally transferring control to the exception handler.

The code field is available for use as software parameters, but is retrieved by the exception handler only by loading the contents of the memory word containing the instruction.

Operation:

32, 64 T: BreakpointException

Exceptions:

Breakpoint exception

CACHE Cache CACHE

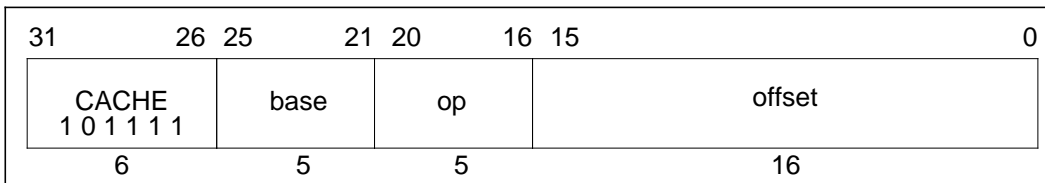
**Format:**

CACHE op, offset(base)

Description:

The 16-bit *offset* is sign-extended and added to the contents of general register *base* to form a virtual address. The virtual address is translated to a physical address using the TLB, and the 5-bit sub-opcode specifies a cache operation for that address.

If CP0 is not usable (User or Supervisor mode) the CP0 enable bit in the *Status* register is clear, and a coprocessor unusable exception is taken. The operation of this instruction on any operation/cache combination not listed below, or on a secondary cache when none is present, is undefined. The operation of this instruction on uncached addresses is also undefined.

The Index operation uses part of the virtual address to specify a cache block.

For a primary cache of $2^{\text{CACHEBITS}}$ bytes with 2^{LINEBITS} bytes per tag, $\text{vAddr}_{\text{CACHEBITS} \dots \text{LINEBITS}}$ specifies the block.

For a secondary cache of $2^{\text{CACHEBITS}}$ bytes with 2^{LINEBITS} bytes per tag, $\text{pAddr}_{\text{CACHEBITS} \dots \text{LINEBITS}}$ specifies the block.

Index Load Tag also uses $\text{vAddr}_{\text{LINEBITS} \dots 3}$ to select the doubleword for reading ECC or parity. When the *CE* bit of the *Status* register is set, Hit WriteBack, Hit WriteBack Invalidate, Index WriteBack Invalidate, and Fill also use $\text{vAddr}_{\text{LINEBITS} \dots 3}$ to select the doubleword that has its ECC or parity modified. This operation is performed unconditionally.

The Hit operation accesses the specified cache as normal data references, and performs the specified operation if the cache block contains valid data with the specified physical address (a hit). If the cache block is invalid or contains a different address (a miss), no operation is performed.

CACHE**Cache
(continued)****CACHE**

Write back from a primary cache goes to the secondary cache (if there is one), otherwise to memory. Write back from a secondary cache always goes to memory. A secondary write back always writes the most recent data; the data comes from the primary data cache, if present, and modified (the *W* bit is set). Otherwise the data comes from the specified secondary cache. The address to be written is specified by the cache tag and not the translated physical address.

TLB Refill and TLB Invalid exceptions can occur on any operation. For Index operations (where the physical address is used to index the cache but need not match the cache tag) unmapped addresses may be used to avoid TLB exceptions. This operation never causes TLB Modified or Virtual Coherency exceptions.

Bits 17...16 of the instruction specify the cache as follows:

Code	Name	Cache
0	I	primary instruction
1	D	primary data
2	SI	secondary instruction
3	SD	secondary data (or combined instruction/data)

CACHE

Cache
(continued)

CACHE

Bits 20...18 (this value is listed under the **Code** column) of the instruction specify the operation as follows:

Code	Caches	Name	Operation
0	I, SI	Index Invalidate	Set the cache state of the cache block to Invalid.
0	D	Index Writeback Invalidate	Examine the cache state and Writeback bit (<i>W</i> bit) of the primary data cache block at the index specified by the virtual address. If the state is not Invalid and the <i>W</i> bit is set, write the block back to the secondary cache (if present) or to memory (if no secondary cache). The address to write is taken from the primary cache tag. When a secondary cache is present, and the <i>CE</i> bit of the <i>Status</i> register is set, the contents of the <i>ECC</i> register is XOR'd into the computed check bits during the write to the secondary cache for the addressed doubleword. Set the cache state of primary cache block to Invalid. The <i>W</i> bit is unchanged (and irrelevant because the state is Invalid).
0	SD	Index Writeback Invalidate	Examine the cache state of the secondary data cache block at the index specified by the physical address. If the block is dirty (the state is Dirty Exclusive or Dirty Shared), write the data back to memory. Like all secondary writebacks, the operation writes any modified data for the addresses from the primary data cache. The address to write is taken from the secondary cache tag. The <i>Pldx</i> field of the secondary tag is used to determine the locations in the primaries to check for matching primary blocks. In all cases, set the state of the secondary cache block and all matching primary subblocks to Invalid. No Invalidate is sent on the R4000's system interface.
1	All	Index Load Tag	Read the tag for the cache block at the specified index and place it into the <i>TagLo</i> and <i>TagHi</i> CP0 registers, ignoring any ECC or parity errors. Also load the data ECC or parity bits into the ECC register.
2	All	Index Store Tag	Write the tag for the cache block at the specified index from the <i>TagLo</i> and <i>TagHi</i> CP0 registers. The processor uses computed parity for the primary caches and the <i>TagLo</i> register in the case of the secondary cache.

CACHE

Cache
(continued)

CACHE

Code	Caches	Name	Operation
3	SD	Create Dirty Exclusive	This operation is used to avoid loading data needlessly from memory when writing new contents into an entire cache block. If the cache block is valid but does not contain the specified address (a valid miss) the secondary block is vacated. The data is written back to memory if dirty and all matching blocks in both primary caches are invalidated. As usual during a secondary writeback, if the primary data cache contains modified data (matching blocks with <i>W</i> bit set) that modified data is written to memory. If the cache block is valid and contains the specified physical address (a hit), the operation cleans up the primary caches to avoid virtual aliases: all blocks in both primary caches that match the secondary line are invalidated without writeback. Note that the search for matching primary blocks uses the virtual index of the <i>PIdx</i> field of the secondary cache tag (the virtual index when the location was last used) and not the virtual index of the virtual address used in the operation (the virtual index where the location will now be used). If the secondary tag and address do not match (miss), or the tag and address do match (hit) and the block is in a shared state, an invalidate for the specified address is sent over the System interface. In all cases, the cache block tag must be set to the specified physical address, the cache state must be set to Dirty Exclusive, and the virtual index field set from the virtual address. The <i>CH</i> bit in the <i>Status</i> register is set or cleared to indicate a hit or miss.
3	D	Create Dirty Exclusive	This operation is used to avoid loading data needlessly from secondary cache or memory when writing new contents into an entire cache block. If the cache block does not contain the specified address, and the block is dirty, write it back to the secondary cache (if present) or otherwise to memory. In all cases, set the cache block tag to the specified physical address, set the cache state to Dirty Exclusive.
4	I,D	Hit Invalidate	If the cache block contains the specified address, mark the cache block invalid.
4	SI, SD	Hit Invalidate	If the cache block contains the specified address, mark the cache block invalid and also invalidate all matching blocks, if present, in the primary caches (the <i>PIdx</i> field of the secondary tag is used to determine the locations in the primaries to search). The <i>CH</i> bit in the <i>Status</i> register is set or cleared to indicate a hit or miss.
5	D	Hit Writeback Invalidate	If the cache block contains the specified address, write the data back if it is dirty, and mark the cache block invalid. When a secondary cache is present, and the <i>CE</i> bit of the <i>Status</i> register is set, the contents of the <i>ECC</i> register is XOR'd into the computed check bits during the write to the secondary cache for the addressed doubleword.

CACHE Cache (continued) CACHE

Code	Caches	Name	Operation
5	SD	Hit Writeback Invalidate	If the cache block contains the specified address, write back the data (if dirty), and mark the secondary cache block and all matching blocks in both primary caches invalid. As usual with secondary writebacks, modified data in the primary data cache (matching block with the <i>W</i> bit set) is used during the writeback. The <i>Pidx</i> field of the secondary tag is used to determine the locations in the primaries to check for matching primary blocks. The <i>CH</i> bit in the <i>Status</i> register is set or cleared to indicate a hit or miss.
5	I	Fill	Fill the primary instruction cache block from secondary cache or memory. If the <i>CE</i> bit of the <i>Status</i> register is set, the content of the <i>ECC</i> register is used instead of the computed parity bits for addressed doubleword when written to the instruction cache. For the R4000PC, the cache is filled from memory. For the R4000SC and R4000MC, the cache is filled from the secondary cache whether or not the secondary cache block is valid or contains the specified address.
6	D	Hit Writeback	If the cache block contains the specified address, and the <i>W</i> bit is set, write back the data. The <i>W</i> bit is not cleared; a subsequent miss to the block will write it back again. This second writeback is redundant, but not incorrect. When a secondary cache is present, and the <i>CE</i> bit of the <i>Status</i> register is set, the content of the <i>ECC</i> register is XOR'd into the computed check bits during the write to the secondary cache for the addressed doubleword. Note: The <i>W</i> bit is not cleared during this operation due to an artifact of the implementation; the <i>W</i> bit is implemented as part of the data side of the cache array so that it can be written during a data write.
6	SD	Hit Writeback	If the cache block contains the specified address, and the cache state is Dirty Exclusive or Dirty Shared, data is written back to memory. The cache state is unchanged; a subsequent miss to the block causes it to be written back again. This second writeback is redundant, but not incorrect. The <i>CH</i> bit in the <i>Status</i> register is set or cleared to indicate a hit or miss. The writeback looks in the primary data cache for modified data, but does not invalidate or clear the Writeback bit in the primary data cache. Note: The state of the secondary block is not changed to clean during this operation because the <i>W</i> bit of matching sub-blocks cannot be cleared to put the primary block in a clean state.
6	I	Hit Writeback	If the cache block contains the specified address, data is written back unconditionally. When a secondary cache is present, and the <i>CE</i> bit of the <i>Status</i> register is set, the contents of the <i>ECC</i> register is XOR'd into the computed check bits during the write to the secondary cache for the addressed doubleword.

CACHE**Cache
(continued)****CACHE**

Code	Caches	Name	Operation
7	SI,SD	Hit Set Virtual	This operation is used to change the virtual index of secondary cache contents, avoiding unnecessary memory operations. If the cache block contains the specified address, invalidate matching blocks in the primary caches at the index formed by concatenating <i>PIdx</i> in the secondary cache tag (not the virtual address of the operation) and <i>vAddr_{11..4}</i> , and then set the virtual index field of the secondary cache tag from the specified virtual address. Modified data in the primary data cache is not preserved by the operation and should be explicitly written back before this operation. The <i>CH</i> bit in the <i>Status</i> register is set or cleared to indicate a hit or miss.

Operation:

32, 64	T:	$vAddr \leftarrow ((offset_{15})^{48} \parallel offset_{15..0}) + GPR[base]$ $(pAddr, uncached) \leftarrow AddressTranslation(vAddr, DATA)$ CacheOp (op, vAddr, pAddr)
--------	----	--

Exceptions:

Coprocesor unusable exception

CFCz Move Control From Coprocessor CFCz

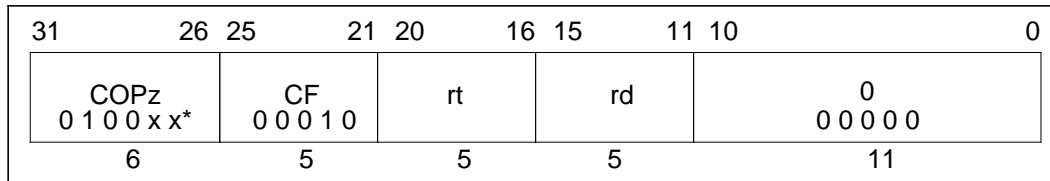

Format:

CFCz rt, rd

Description:

The contents of coprocessor control register *rd* of coprocessor unit *z* are loaded into general register *rt*.

This instruction is not valid for CP0.

Operation:

32	T: data ← CCR[z,rd]
	T+1: GPR[rt] ← data
64	T: data ← (CCR[z,rd] ₃₁) ³² CCR[z,rd]
	T+1: GPR[rt] ← data

Exceptions:

Coprocessor unusable exception

***Opcode Bit Encoding:**

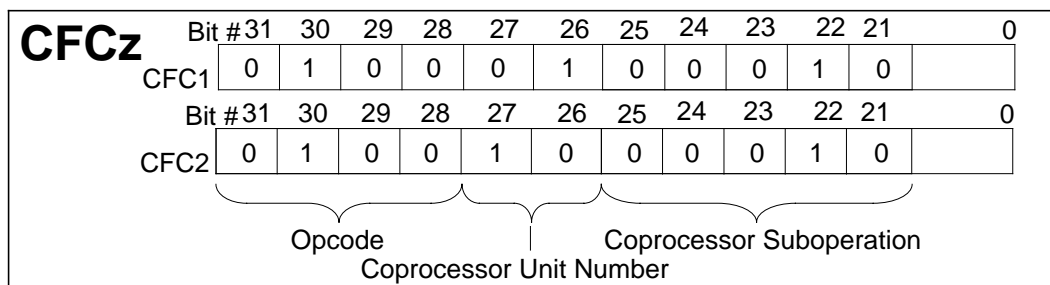

COPz Coprocessor Operation COPz

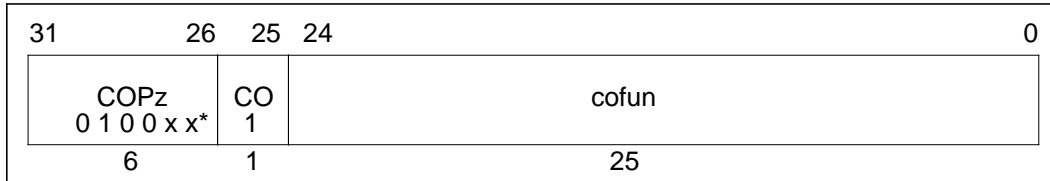

Format:

COPz cofun

Description:

A coprocessor operation is performed. The operation may specify and reference internal coprocessor registers, and may change the state of the coprocessor condition line, but does not modify state within the processor or the cache/memory system. Details of coprocessor operations are contained in Appendix B.

Operation:

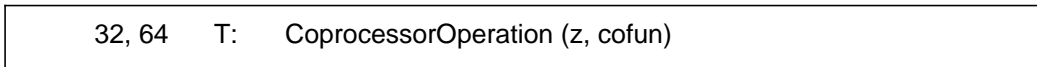

Exceptions:

- Coprocessor unusable exception
- Coprocessor interrupt or Floating-Point Exception (R4000 CP1 only)

***Opcode Bit Encoding:**

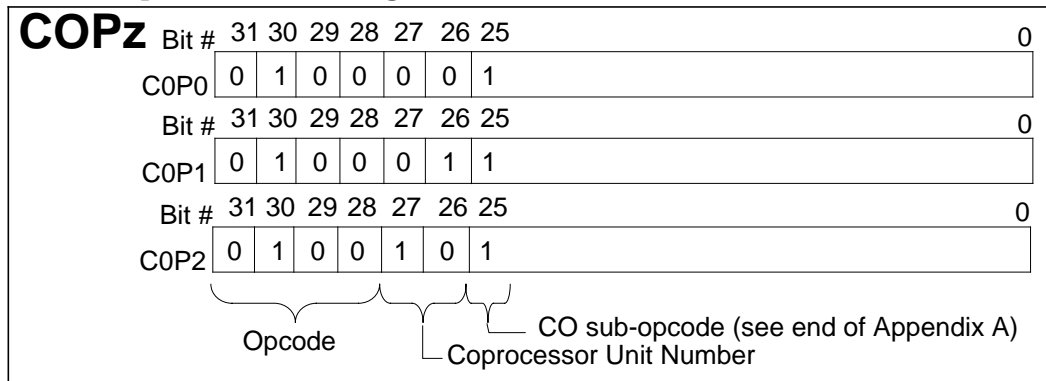

CTCz Move Control to Coprocessor CTCz

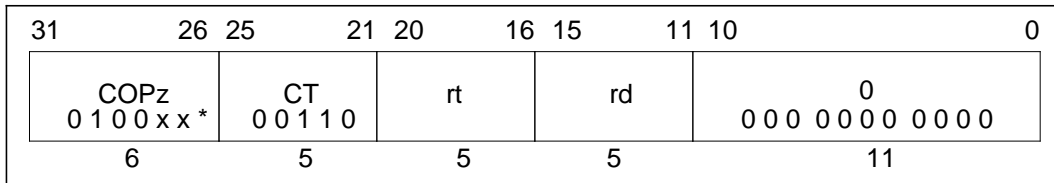
**Format:**

CTCz rt, rd

Description:

The contents of general register *rt* are loaded into control register *rd* of coprocessor unit *z*.

This instruction is not valid for CP0.

Operation:

32,64	T: data ← GPR[rt]
	T + 1: CCR[z,rd] ← data

Exceptions:

Coprocessor unusable

*See “CPU Instruction Opcode Bit Encoding” at the end of Appendix A.

DADD Doubleword Add DADD

31	26	25	21	20	16	15	11	10	6	5	0	
SPECIAL 0 0 0 0 0 0			rs		rt		rd		0 0 0 0 0 0		DADD 1 0 1 1 0 0	
6			5		5		5		5		6	

Format:

DADD rd, rs, rt

Description:

The contents of general register *rs* and the contents of general register *rt* are added to form the result. The result is placed into general register *rd*.

An overflow exception occurs if the carries out of bits 62 and 63 differ (2's complement overflow). The destination register *rd* is not modified when an integer overflow exception occurs.

This operation is only defined for the R4000 operating in 64-bit mode. Execution of this instruction in 32-bit mode causes a reserved instruction exception.

Operation:

64 T: $GPR[rd] \leftarrow GPR[rs] + GPR[rt]$

Exceptions:

Integer overflow exception

Reserved instruction exception (R4000 in 32-bit mode)

DADDI Doubleword Add Immediate DADDI

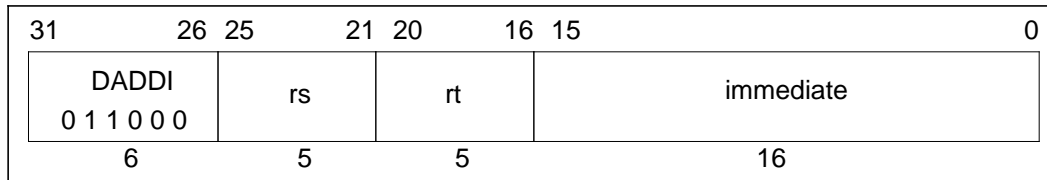
**Format:**DADDI *rt*, *rs*, *immediate***Description:**

The 16-bit *immediate* is sign-extended and added to the contents of general register *rs* to form the result. The result is placed into general register *rt*.

An overflow exception occurs if carries out of bits 62 and 63 differ (2's complement overflow). The destination register *rt* is not modified when an integer overflow exception occurs.

This operation is only defined for the R4000 operating in 64-bit mode. Execution of this instruction in 32-bit mode causes a reserved instruction exception.

Operation:

64	T:	$\text{GPR}[rt] \leftarrow \text{GPR}[rs] + (\text{immediate}_{15})^{48} // \text{immediate}_{15..0}$
----	----	---

Exceptions:

- Integer overflow exception
- Reserved instruction exception (R4000 in 32-bit mode)

DADDIU Doubleword Add Immediate Unsigned DADDIU

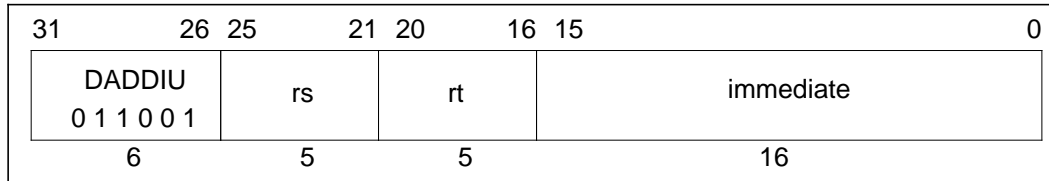
**Format:**

DADDIU rt, rs, immediate

Description:

The 16-bit *immediate* is sign-extended and added to the contents of general register *rs* to form the result. The result is placed into general register *rt*. No integer overflow exception occurs under any circumstances.

The only difference between this instruction and the DADDI instruction is that DADDIU never causes an overflow exception.

This operation is only defined for the R4000 operating in 64-bit mode. Execution of this instruction in 32-bit mode causes a reserved instruction exception.

Operation:

$$64 \quad T: \quad \text{GPR}[rt] \leftarrow \text{GPR}[rs] + (\text{immediate}_{15})^{48} \parallel \text{immediate}_{15\dots 0}$$
Exceptions:

Reserved instruction exception (R4000 in 32-bit mode)

DADDU Doubleword Add Unsigned DADDU

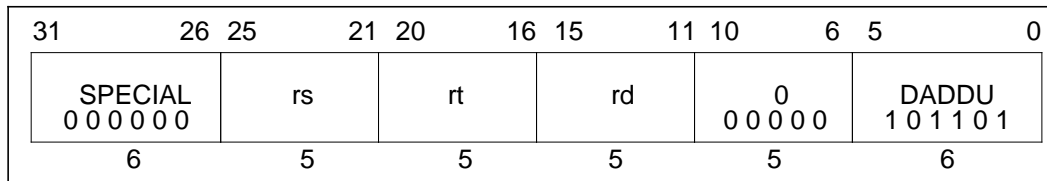
**Format:**

DADDU rd, rs, rt

Description:

The contents of general register *rs* and the contents of general register *rt* are added to form the result. The result is placed into general register *rd*.

No overflow exception occurs under any circumstances.

The only difference between this instruction and the DADD instruction is that DADDU never causes an overflow exception.

This operation is only defined for the R4000 operating in 64-bit mode. Execution of this instruction in 32-bit mode causes a reserved instruction exception.

Operation:

64 T: $GPR[rd] \leftarrow GPR[rs] + GPR[rt]$
--

Exceptions:

Reserved instruction exception (R4000 in 32-bit mode)

DDIV Doubleword Divide DDIV

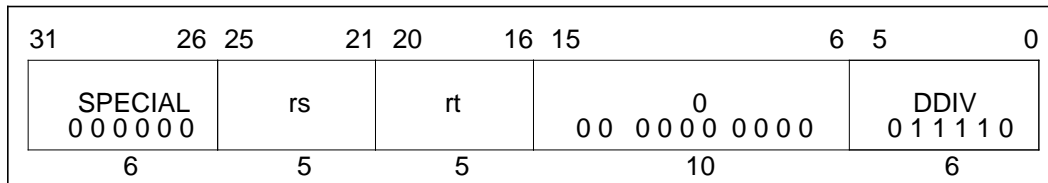
**Format:**

DDIV rs, rt

Description:

The contents of general register *rs* are divided by the contents of general register *rt*, treating both operands as 2's complement values. No overflow exception occurs under any circumstances, and the result of this operation is undefined when the divisor is zero.

This instruction is typically followed by additional instructions to check for a zero divisor and for overflow.

When the operation completes, the quotient word of the double result is loaded into special register *LO*, and the remainder word of the double result is loaded into special register *HI*.

If either of the two preceding instructions is MFHI or MFLO, the results of those instructions are undefined. Correct operation requires separating reads of *HI* or *LO* from writes by two or more instructions.

This operation is only defined for the R4000 operating in 64-bit mode. Execution of this instruction in 32-bit mode causes a reserved instruction exception.

Operation:

64	T-2:	LO	← undefined
		HI	← undefined
	T-1:	LO	← undefined
		HI	← undefined
	T:	LO	← GPR[rs] div GPR[rt]
		HI	← GPR[rs] mod GPR[rt]

Exceptions:

Reserved instruction exception (R4000 in 32-bit mode)

DDIVU Doubleword Divide Unsigned DDIVU

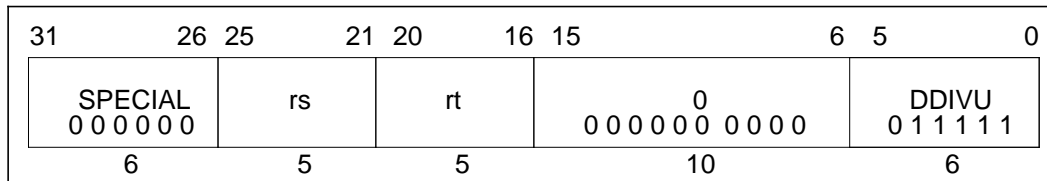
**Format:**

DDIVU rs, rt

Description:

The contents of general register *rs* are divided by the contents of general register *rt*, treating both operands as unsigned values. No integer overflow exception occurs under any circumstances, and the result of this operation is undefined when the divisor is zero.

This instruction is typically followed by additional instructions to check for a zero divisor.

When the operation completes, the quotient word of the double result is loaded into special register *LO*, and the remainder word of the double result is loaded into special register *HI*.

If either of the two preceding instructions is MFHI or MFLO, the results of those instructions are undefined. Correct operation requires separating reads of *HI* or *LO* from writes by two or more instructions.

This operation is only defined for the R4000 operating in 64-bit mode. Execution of this instruction in 32-bit mode causes a reserved instruction exception.

Operation:

64	T-2:	LO	← undefined
		HI	← undefined
	T-1:	LO	← undefined
		HI	← undefined
	T:	LO	← (0 GPR[rs]) div (0 GPR[rt])
		HI	← (0 GPR[rs]) mod (0 GPR[rt])

Exceptions:

Reserved instruction exception (R4000 in 32-bit mode)

DIV Divide DIV

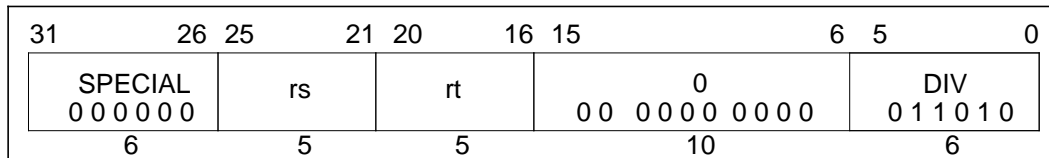
**Format:**

DIV rs, rt

Description:

The contents of general register *rs* are divided by the contents of general register *rt*, treating both operands as 2's complement values. No overflow exception occurs under any circumstances, and the result of this operation is undefined when the divisor is zero.

In 64-bit mode, the operands must be valid sign-extended, 32-bit values.

This instruction is typically followed by additional instructions to check for a zero divisor and for overflow.

When the operation completes, the quotient word of the double result is loaded into special register *LO*, and the remainder word of the double result is loaded into special register *HI*.

If either of the two preceding instructions is MFHI or MFLO, the results of those instructions are undefined. Correct operation requires separating reads of *HI* or *LO* from writes by two or more instructions.

DIV**Divide
(continued)****DIV****Operation:**

32	T-2:	LO	\leftarrow undefined
		HI	\leftarrow undefined
	T-1:	LO	\leftarrow undefined
		HI	\leftarrow undefined
T:	LO	\leftarrow GPR[rs] div GPR[rt]	
	HI	\leftarrow GPR[rs] mod GPR[rt]	
64	T-2:	LO	\leftarrow undefined
		HI	\leftarrow undefined
	T-1:	LO	\leftarrow undefined
		HI	\leftarrow undefined
	T:	q	\leftarrow GPR[rs] _{31...0} div GPR[rt] _{31...0}
		r	\leftarrow GPR[rs] _{31...0} mod GPR[rt] _{31...0}
		LO	\leftarrow (q ₃₁) ³² q _{31...0}
		HI	\leftarrow (r ₃₁) ³² r _{31...0}

Exceptions:

None

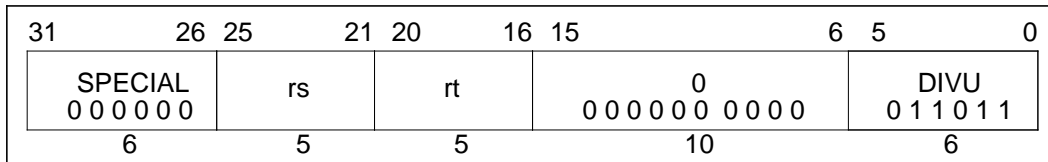
DIVU**Divide Unsigned****DIVU****Format:**

DIVU rs, rt

Description:

The contents of general register *rs* are divided by the contents of general register *rt*, treating both operands as unsigned values. No integer overflow exception occurs under any circumstances, and the result of this operation is undefined when the divisor is zero.

In 64-bit mode, the operands must be valid sign-extended, 32-bit values.

This instruction is typically followed by additional instructions to check for a zero divisor.

When the operation completes, the quotient word of the double result is loaded into special register *LO*, and the remainder word of the double result is loaded into special register *HI*.

If either of the two preceding instructions is MFHI or MFLO, the results of those instructions are undefined. Correct operation requires separating reads of *HI* or *LO* from writes by two or more instructions.

DIVU**Divide Unsigned
(continued)****DIVU****Operation:**

32	T-2:	LO	\leftarrow undefined
		HI	\leftarrow undefined
	T-1:	LO	\leftarrow undefined
		HI	\leftarrow undefined
	T:	LO	$\leftarrow (0 \parallel \text{GPR}[\text{rs}]) \text{ div } (0 \parallel \text{GPR}[\text{rt}])$
		HI	$\leftarrow (0 \parallel \text{GPR}[\text{rs}]) \text{ mod } (0 \parallel \text{GPR}[\text{rt}])$
64	T-2:	LO	\leftarrow undefined
		HI	\leftarrow undefined
	T-1:	LO	\leftarrow undefined
		HI	\leftarrow undefined
	T:	q	$\leftarrow (0 \parallel \text{GPR}[\text{rs}]_{31\dots 0}) \text{ div } (0 \parallel \text{GPR}[\text{rt}]_{31\dots 0})$
		r	$\leftarrow (0 \parallel \text{GPR}[\text{rs}]_{31\dots 0}) \text{ mod } (0 \parallel \text{GPR}[\text{rt}]_{31\dots 0})$
		LO	$\leftarrow (q_{31})^{32} \parallel q_{31\dots 0}$
		HI	$\leftarrow (r_{31})^{32} \parallel r_{31\dots 0}$

Exceptions:

None

DMFC0 Doubleword Move From System Control Coprocessor DMFC0

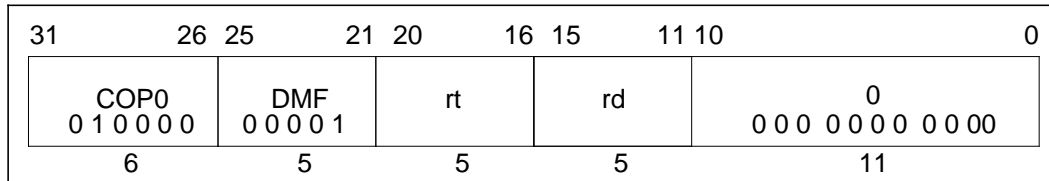
**Format:**

DMFC0 rt, rd

Description:

The contents of coprocessor register *rd* of the CP0 are loaded into general register *rt*.

This operation is defined for the R4000 operating in 64-bit mode and in 32-bit kernel mode. Execution of this instruction in 32-bit user or supervisor mode causes a reserved instruction exception. All 64-bits of the general register destination are written from the coprocessor register source. The operation of DMFC0 on a 32-bit coprocessor 0 register is undefined.

Operation:

64	T: data ← CPR[0,rd]
	T+1: GPR[rt] ← data

Exceptions:

Coprocessor unusable exception
 Reserved instruction exception (R4000 in 32-bit user mode
 R4000 in 32-bit supervisor mode)

DMTC0 Doubleword Move To System Control Coprocessor DMTC0

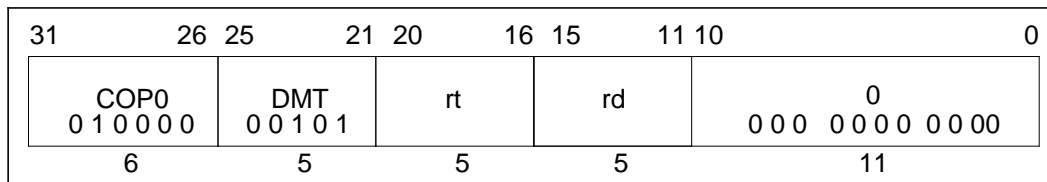
**Format:**

DMTC0 rt, rd

Description:

The contents of general register *rt* are loaded into coprocessor register *rd* of the CP0.

This operation is defined for the R4000 operating in 64-bit mode or in 32-bit kernel mode. Execution of this instruction in 32-bit user or supervisor mode causes a reserved instruction exception.

All 64-bits of the coprocessor 0 register are written from the general register source. The operation of DMTC0 on a 32-bit coprocessor 0 register is undefined.

Because the state of the virtual address translation system may be altered by this instruction, the operation of load instructions, store instructions, and TLB operations immediately prior to and after this instruction are undefined.

Operation:

64	T: data ← GPR[rt]
	T+1: CPR[0,rd] ← data

Exceptions:

Coprocessor unusable exception (R4000 in 32-bit user mode
R4000 in 32-bit supervisor mode)

DMULT Doubleword Multiply DMULT

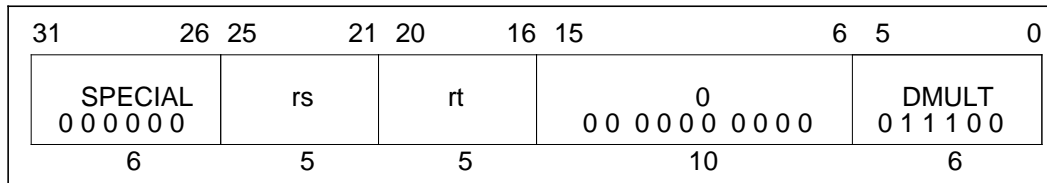
**Format:**

DMULT rs, rt

Description:

The contents of general registers *rs* and *rt* are multiplied, treating both operands as 2's complement values. No integer overflow exception occurs under any circumstances.

When the operation completes, the low-order word of the double result is loaded into special register *LO*, and the high-order word of the double result is loaded into special register *HI*.

If either of the two preceding instructions is MFHI or MFLO, the results of these instructions are undefined. Correct operation requires separating reads of *HI* or *LO* from writes by a minimum of two other instructions.

This operation is only defined for the R4000 operating in 64-bit mode. Execution of this instruction in 32-bit mode causes a reserved instruction exception.

Operation:

64	T-2:	LO	← undefined
		HI	← undefined
	T-1:	LO	← undefined
		HI	← undefined
	T:	t	← GPR[rs] * GPR[rt]
		LO	← t _{63...0}
		HI	← t _{127...64}

Exceptions:

Reserved instruction exception (R4000 in 32-bit mode)

DMULTU Doubleword Multiply Unsigned DMULTU

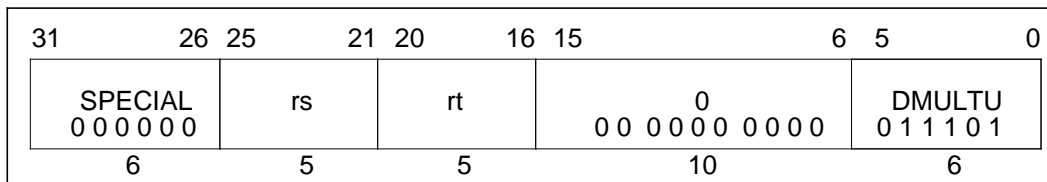
**Format:**

DMULTU rs, rt

Description:

The contents of general register *rs* and the contents of general register *rt* are multiplied, treating both operands as unsigned values. No overflow exception occurs under any circumstances.

When the operation completes, the low-order word of the double result is loaded into special register *LO*, and the high-order word of the double result is loaded into special register *HI*.

If either of the two preceding instructions is MFHI or MFLO, the results of these instructions are undefined. Correct operation requires separating reads of *HI* or *LO* from writes by a minimum of two instructions.

This operation is only defined for the R4000 operating in 64-bit mode. Execution of this instruction in 32-bit mode causes a reserved instruction exception.

Operation:

64	T-2:	LO ← undefined HI ← undefined
	T-1:	LO ← undefined HI ← undefined
	T:	$t \leftarrow (0 \parallel \text{GPR}[rs]) * (0 \parallel \text{GPR}[rt])$ LO ← $t_{63..0}$ HI ← $t_{127..64}$

Exceptions:

Reserved instruction exception (R4000 in 32-bit mode)

DSLL Doubleword Shift Left Logical DSLL

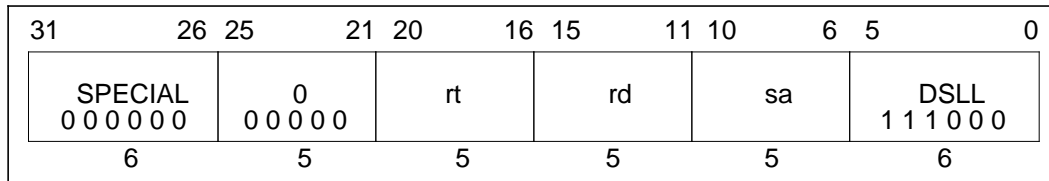
**Format:**

DSLL rd, rt, sa

Description:

The contents of general register *rt* are shifted left by *sa* bits, inserting zeros into the low-order bits. The result is placed in register *rd*.

Operation:

64 T: $s \leftarrow 0 \parallel sa$
 $GPR[rd] \leftarrow GPR[rt]_{(63-s)\dots 0} \parallel 0^s$

Exceptions:

Reserved instruction exception (R4000 in 32-bit mode)

DSLLV Doubleword Shift Left Logical Variable DSLLV

31	26	25	21	20	16	15	11	10	6	5	0
SPECIAL 000000		rs		rt		rd		0 00000		DSLLV 010100	
6		5		5		5		5		6	

Format:

DSLLV rd, rt, rs

Description:

The contents of general register *rt* are shifted left by the number of bits specified by the low-order six bits contained in general register *rs*, inserting zeros into the low-order bits. The result is placed in register *rd*.

This operation is only defined for the R4000 operating in 64-bit mode. Execution of this instruction in 32-bit mode causes a reserved instruction exception.

Operation:

64 T: $s \leftarrow \text{GPR}[\text{rs}]_{5..0}$
 $\text{GPR}[\text{rd}] \leftarrow \text{GPR}[\text{rt}]_{(63-s)..0} \parallel 0^s$

Exceptions:

Reserved instruction exception (R4000 in 32-bit mode)

DSLL32 Doubleword Shift Left Logical + 32 DSLL32

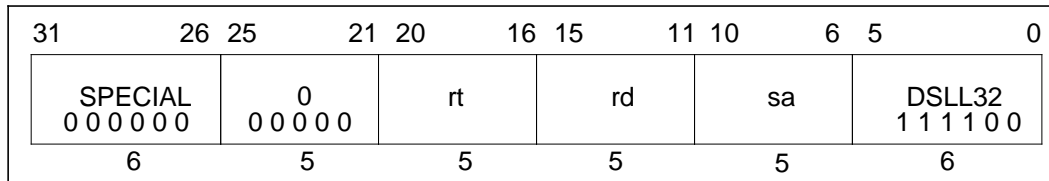
**Format:**

DSLL32 rd, rt, sa

Description:

The contents of general register *rt* are shifted left by $32+sa$ bits, inserting zeros into the low-order bits. The result is placed in register *rd*.

This operation is only defined for the R4000 operating in 64-bit mode. Execution of this instruction in 32-bit mode causes a reserved instruction exception.

Operation:

64	T: $s \leftarrow 1 \parallel sa$ $GPR[rd] \leftarrow GPR[rt]_{(63-s) \dots 0} \parallel 0^s$
----	---

Exceptions:

Reserved instruction exception (R4000 in 32-bit mode)

DSRA Doubleword DSRA

Shift Right Arithmetic

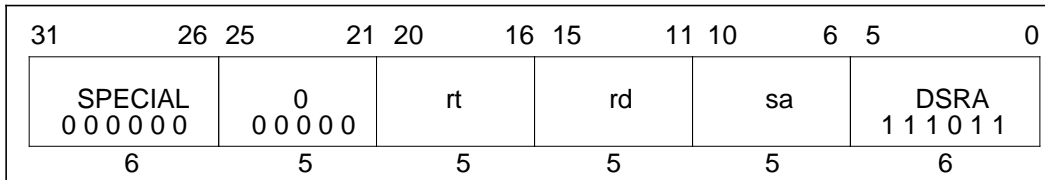
**Format:**

DSRA rd, rt, sa

Description:

The contents of general register *rt* are shifted right by *sa* bits, sign-extending the high-order bits. The result is placed in register *rd*.

This operation is only defined for the R4000 operating in 64-bit mode. Execution of this instruction in 32-bit mode causes a reserved instruction exception.

Operation:

64 T: $s \leftarrow 0 \parallel sa$
 $GPR[rd] \leftarrow (GPR[rt]_{63})^s \parallel GPR[rt]_{63...s}$

Exceptions:

Reserved instruction exception (R4000 in 32-bit mode)

DSRAV Doubleword Shift Right Arithmetic Variable DSRAV

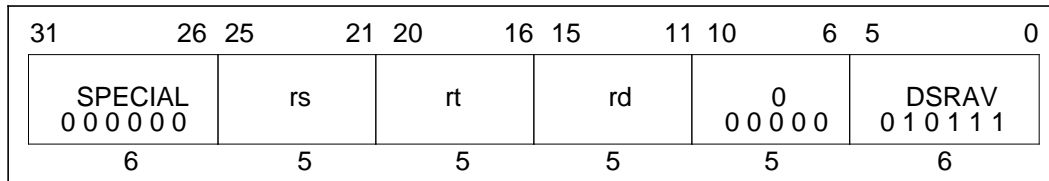
**Format:**

DSRAV rd, rt, rs

Description:

The contents of general register *rt* are shifted right by the number of bits specified by the low-order six bits of general register *rs*, sign-extending the high-order bits. The result is placed in register *rd*.

This operation is only defined for the R4000 operating in 64-bit mode. Execution of this instruction in 32-bit mode causes a reserved instruction exception.

Operation:

64	T:	$s \leftarrow \text{GPR}[rs]_{5..0}$ $\text{GPR}[rd] \leftarrow (\text{GPR}[rt]_{63})^s \parallel \text{GPR}[rt]_{63..s}$
----	----	--

Exceptions:

Reserved instruction exception (R4000 in 32-bit mode)

DSRA32 Doubleword Shift Right Arithmetic + 32 DSRA32

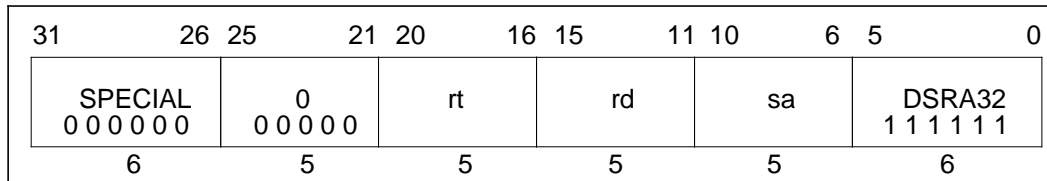
**Format:**

DSRA32 rd, rt, sa

Description:

The contents of general register *rt* are shifted right by $32+sa$ bits, sign-extending the high-order bits. The result is placed in register *rd*.

This operation is only defined for the R4000 operating in 64-bit mode. Execution of this instruction in 32-bit mode causes a reserved instruction exception.

Operation:

64 T: $s \leftarrow 1 \parallel sa$
 $GPR[rd] \leftarrow (GPR[rt]_{63})^s \parallel GPR[rt]_{63...s}$

Exceptions:

Reserved instruction exception (R4000 in 32-bit mode)

DSRL Doubleword DSRL

Shift Right Logical

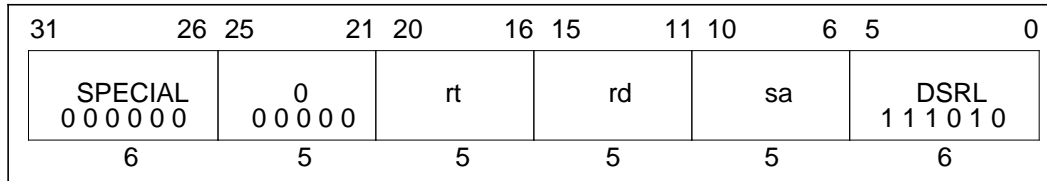
**Format:**

DSRL rd, rt, sa

Description:

The contents of general register *rt* are shifted right by *sa* bits, inserting zeros into the high-order bits. The result is placed in register *rd*.

This operation is only defined for the R4000 operating in 64-bit mode. Execution of this instruction in 32-bit mode causes a reserved instruction exception.

Operation:

64 T: $s \leftarrow 0 \parallel sa$
 $GPR[rd] \leftarrow 0^s \parallel GPR[rt]_{63..s}$

Exceptions:

Reserved instruction exception (R4000 in 32-bit mode)

DSRLV Doubleword Shift Right Logical Variable DSRLV

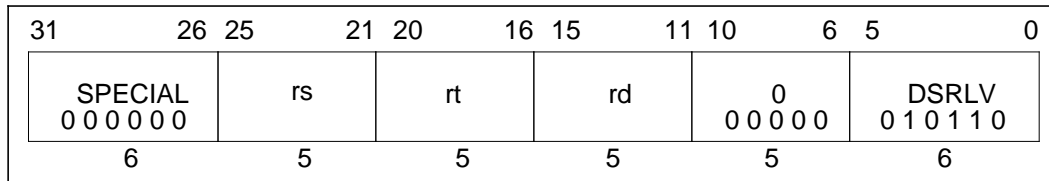
**Format:**

DSRLV rd, rt, rs

Description:

The contents of general register *rt* are shifted right by the number of bits specified by the low-order six bits of general register *rs*, inserting zeros into the high-order bits. The result is placed in register *rd*.

This operation is only defined for the R4000 operating in 64-bit mode. Execution of this instruction in 32-bit mode causes a reserved instruction exception.

Operation:

64	T: $s \leftarrow \text{GPR}[rs]_{5..0}$ $\text{GPR}[rd] \leftarrow 0^s \parallel \text{GPR}[rt]_{63..s}$
----	---

Exceptions:

Reserved instruction exception (R4000 in 32-bit mode)

DSRL32 Doubleword Shift Right Logical + 32 DSRL32

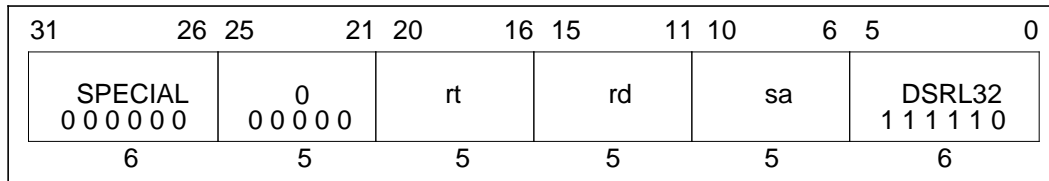
**Format:**

DSRL32 rd, rt, sa

Description:

The contents of general register *rt* are shifted right by $32+sa$ bits, inserting zeros into the high-order bits. The result is placed in register *rd*.

This operation is only defined for the R4000 operating in 64-bit mode. Execution of this instruction in 32-bit mode causes a reserved instruction exception.

Operation:

64 T: $s \leftarrow 1 \parallel sa$
 $GPR[rd] \leftarrow 0^s \parallel GPR[rt]_{63\dots s}$

Exceptions:

Reserved instruction exception (R4000 in 32-bit mode)

DSUB Doubleword Subtract DSUB

31	26 25	21 20	16 15	11 10	6 5	0
SPECIAL 000000	rs	rt	rd	0 00000	DSUB 101110	
6	5	5	5	5	6	

Format:

DSUB rd, rs, rt

Description:

The contents of general register *rt* are subtracted from the contents of general register *rs* to form a result. The result is placed into general register *rd*.

The only difference between this instruction and the DSUBU instruction is that DSUBU never traps on overflow.

An integer overflow exception takes place if the carries out of bits 62 and 63 differ (2's complement overflow). The destination register *rd* is not modified when an integer overflow exception occurs.

This operation is only defined for the R4000 operating in 64-bit mode. Execution of this instruction in 32-bit mode causes a reserved instruction exception.

Operation:

64	T: $GPR[rd] \leftarrow GPR[rs] - GPR[rt]$
----	---

Exceptions:

Integer overflow exception
Reserved instruction exception (R4000 in 32-bit mode)

DSUBU Doubleword Subtract Unsigned DSUBU

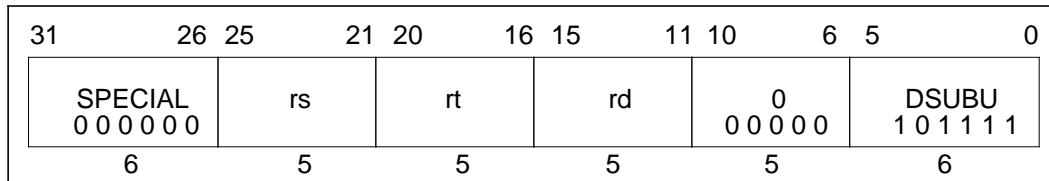
**Format:**

DSUBU rd, rs, rt

Description:

The contents of general register *rt* are subtracted from the contents of general register *rs* to form a result. The result is placed into general register *rd*.

The only difference between this instruction and the DSUB instruction is that DSUBU never traps on overflow. No integer overflow exception occurs under any circumstances.

This operation is only defined for the R4000 operating in 64-bit mode. Execution of this instruction in 32-bit mode causes a reserved instruction exception.

Operation:

64	T: $GPR[rd] \leftarrow GPR[rs] - GPR[rt]$
----	---

Exceptions:

Reserved instruction exception (R4000 in 32-bit mode)

ERET Exception Return ERET

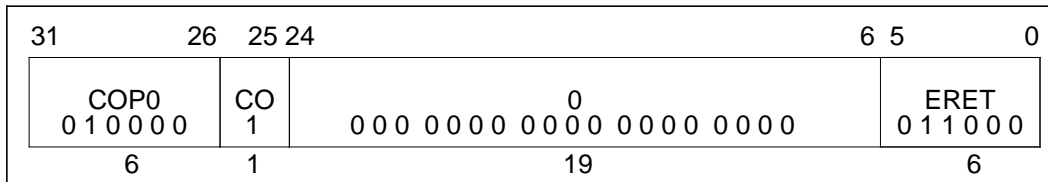
**Format:**

ERET

Description:

ERET is the R4000 instruction for returning from an interrupt, exception, or error trap. Unlike a branch or jump instruction, ERET does not execute the next instruction.

ERET must not itself be placed in a branch delay slot.

If the processor is servicing an error trap ($SR_2 = 1$), then load the PC from the *ErrorEPC* and clear the *ERL* bit of the *Status* register (SR_2). Otherwise ($SR_2 = 0$), load the PC from the *EPC*, and clear the *EXL* bit of the *Status* register (SR_1).

An ERET executed between a LL and SC also causes the SC to fail.

Operation:

32, 64	<pre> T: if $SR_2 = 1$ then PC ← ErrorEPC SR ← $SR_{31...3} 0 SR_{1...0}$ else PC ← EPC SR ← $SR_{31...2} 0 SR_0$ endif LLbit ← 0 </pre>
--------	---

Exceptions:

Coprocessor unusable exception

J Jump J

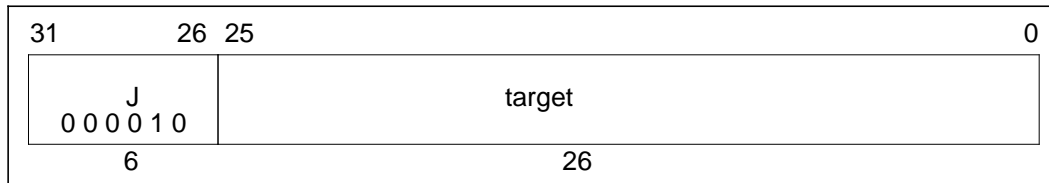
**Format:**

J target

Description:

The 26-bit target address is shifted left two bits and combined with the high-order bits of the address of the delay slot. The program unconditionally jumps to this calculated address with a delay of one instruction.

Operation:

32	T: temp ← target T+1: PC ← PC _{31...28} temp 0 ²
64	T: temp ← target T+1: PC ← PC _{63...28} temp 0 ²

Exceptions:

None

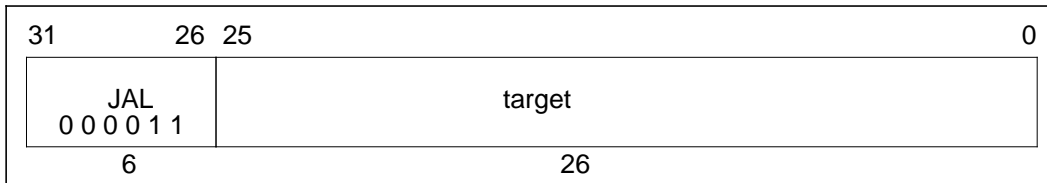
JAL**Jump And Link****JAL****Format:**

JAL target

Description:

The 26-bit target address is shifted left two bits and combined with the high-order bits of the address of the delay slot. The program unconditionally jumps to this calculated address with a delay of one instruction. The address of the instruction after the delay slot is placed in the link register, *r31*.

Operation:

32	T: temp ← target GPR[31] ← PC + 8 T+1: PC ← PC _{31...28} temp 0 ²
64	T: temp ← target GPR[31] ← PC + 8 T+1: PC ← PC _{63...28} temp 0 ²

Exceptions:

None

JALR Jump And Link Register JALR

31	26 25	21 20	16 15	11 10	6 5	0
SPECIAL 000000	rs	0 00000	rd	0 00000	JALR 001001	
6	5	5	5	5	6	

Format:

JALR rs
JALR rd, rs

Description:

The program unconditionally jumps to the address contained in general register *rs*, with a delay of one instruction. The address of the instruction after the delay slot is placed in general register *rd*. The default value of *rd*, if omitted in the assembly language instruction, is 31.

Register specifiers *rs* and *rd* may not be equal, because such an instruction does not have the same effect when re-executed. However, an attempt to execute this instruction is *not* trapped, and the result of executing such an instruction is undefined.

Since instructions must be word-aligned, a **Jump and Link Register** instruction must specify a target register (*rs*) whose two low-order bits are zero. If these low-order bits are not zero, an address exception will occur when the jump target instruction is subsequently fetched.

Operation:

32, 64	T:	temp ← GPR [rs] GPR[rd] ← PC + 8
	T+1:	PC ← temp

Exceptions:

None

LB Load Byte LB

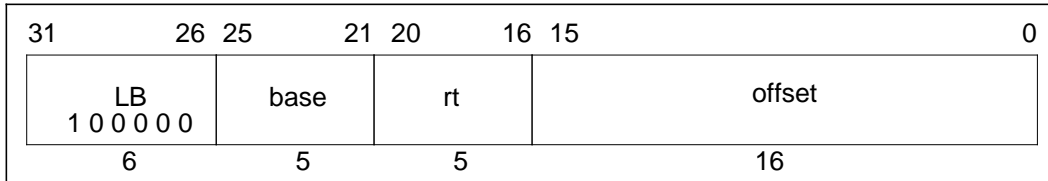
**Format:**

LB rt, offset(base)

Description:

The 16-bit *offset* is sign-extended and added to the contents of general register *base* to form a virtual address. The contents of the byte at the memory location specified by the effective address are sign-extended and loaded into general register *rt*.

Operation:

32	T:	$vAddr \leftarrow ((offset_{15})^{16} \parallel offset_{15..0}) + GPR[base]$ $(pAddr, uncached) \leftarrow AddressTranslation(vAddr, DATA)$ $pAddr \leftarrow pAddr_{PSIZE-1..3} \parallel (pAddr_{2..0} \text{ xor } ReverseEndian^3)$ $mem \leftarrow LoadMemory(uncached, BYTE, pAddr, vAddr, DATA)$ $byte \leftarrow vAddr_{2..0} \text{ xor } BigEndianCPU^3$ $GPR[rt] \leftarrow (mem_{7+8*byte})^{24} \parallel mem_{7+8*byte..8*byte}$
64	T:	$vAddr \leftarrow ((offset_{15})^{48} \parallel offset_{15..0}) + GPR[base]$ $(pAddr, uncached) \leftarrow AddressTranslation(vAddr, DATA)$ $pAddr \leftarrow pAddr_{PSIZE-1..3} \parallel (pAddr_{2..0} \text{ xor } ReverseEndian^3)$ $mem \leftarrow LoadMemory(uncached, BYTE, pAddr, vAddr, DATA)$ $byte \leftarrow vAddr_{2..0} \text{ xor } BigEndianCPU^3$ $GPR[rt] \leftarrow (mem_{7+8*byte})^{56} \parallel mem_{7+8*byte..8*byte}$

Exceptions:

- TLB refill exception
- TLB invalid exception
- Bus error exception
- Address error exception

LBU Load Byte Unsigned LBU

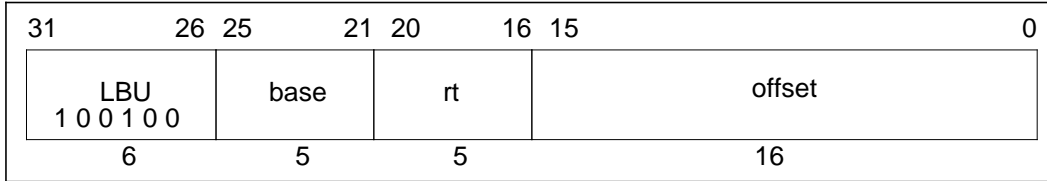
**Format:**LBU *rt*, *offset*(*base*)**Description:**

The 16-bit *offset* is sign-extended and added to the contents of general register *base* to form a virtual address. The contents of the byte at the memory location specified by the effective address are zero-extended and loaded into general register *rt*.

Operation:

32	T:	$vAddr \leftarrow ((offset_{15})^{16} \parallel offset_{15..0}) + GPR[base]$ $(pAddr, uncached) \leftarrow AddressTranslation(vAddr, DATA)$ $pAddr \leftarrow pAddr_{P_SIZE-1..3} \parallel (pAddr_{2..0} \text{ xor } ReverseEndian^3)$ $mem \leftarrow LoadMemory(uncached, BYTE, pAddr, vAddr, DATA)$ $byte \leftarrow vAddr_{2..0} \text{ xor } BigEndianCPU^3$ $GPR[rt] \leftarrow 0^{24} \parallel mem_{7+8*byte..8*byte}$
64	T:	$vAddr \leftarrow ((offset_{15})^{48} \parallel offset_{15..0}) + GPR[base]$ $(pAddr, uncached) \leftarrow AddressTranslation(vAddr, DATA)$ $pAddr \leftarrow pAddr_{P_SIZE-1..3} \parallel (pAddr_{2..0} \text{ xor } ReverseEndian^3)$ $mem \leftarrow LoadMemory(uncached, BYTE, pAddr, vAddr, DATA)$ $byte \leftarrow vAddr_{2..0} \text{ xor } BigEndianCPU^3$ $GPR[rt] \leftarrow 0^{56} \parallel mem_{7+8*byte..8*byte}$

Exceptions:

TLB refill exception
Bus error exception

TLB invalid exception
Address error exception

LD Load Doubleword LD

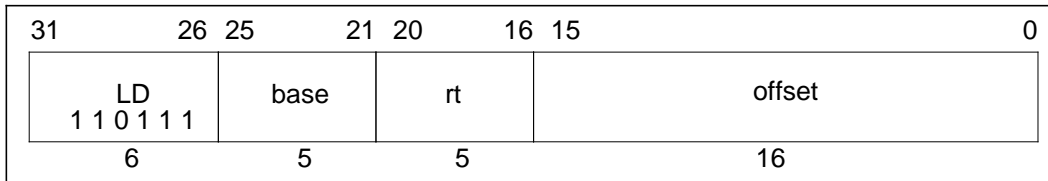
**Format:**LD *rt*, offset(*base*)**Description:**

The 16-bit *offset* is sign-extended and added to the contents of general register *base* to form a virtual address. The contents of the 64-bit doubleword at the memory location specified by the effective address are loaded into general register *rt*.

If any of the three least-significant bits of the effective address are non-zero, an address error exception occurs.

This operation is only defined for the R4000 operating in 64-bit mode. Execution of this instruction in 32-bit mode causes a reserved instruction exception.

Operation:

64 T: $vAddr \leftarrow ((offset_{15})^{48} \parallel offset_{15...0}) + GPR[base]$
 $(pAddr, uncached) \leftarrow AddressTranslation(vAddr, DATA)$
 $mem \leftarrow LoadMemory(uncached, DOUBLEWORD, pAddr, vAddr, DATA)$
 $GPR[rt] \leftarrow mem$

Exceptions:

- TLB refill exception
- TLB invalid exception
- Bus error exception
- Address error exception
- Reserved instruction exception (R4000 in 32-bit user mode
R4000 in 32-bit supervisor mode)

LDCz Load Doubleword To Coprocessor LDCz

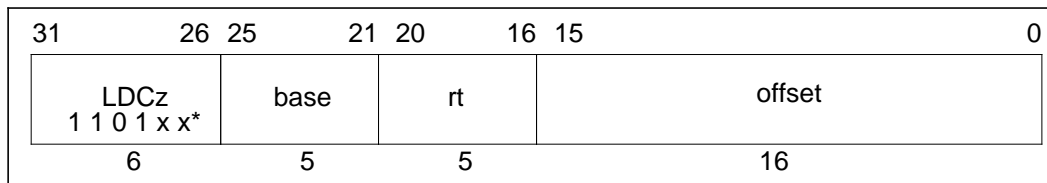
**Format:**

LDCz rt, offset(base)

Description:

The 16-bit *offset* is sign-extended and added to the contents of general register *base* to form a virtual address. The processor reads a doubleword from the addressed memory location and makes the data available to coprocessor unit *z*. The manner in which each coprocessor uses the data is defined by the individual coprocessor specifications.

If any of the three least-significant bits of the effective address are non-zero, an address error exception takes place.

This instruction is not valid for use with CP0.

This instruction is undefined when the least-significant bit of the *rt* field is non-zero.

*See the table "Opcode Bit Encoding" on next page, or "CPU Instruction Opcode Bit Encoding" at the end of Appendix A.

LDCz Load Doubleword To Coprocessor (continued) LDCz

Operation:

32	T:	$vAddr \leftarrow ((offset_{15})^{16} \parallel offset_{15..0}) + GPR[base]$ $(pAddr, uncached) \leftarrow AddressTranslation(vAddr, DATA)$ $mem \leftarrow LoadMemory(uncached, DOUBLEWORD, pAddr, vAddr, DATA)$ COPzLD (rt, mem)
64	T:	$vAddr \leftarrow ((offset_{15})^{48} \parallel offset_{15..0}) + GPR[base]$ $(pAddr, uncached) \leftarrow AddressTranslation(vAddr, DATA)$ $mem \leftarrow LoadMemory(uncached, DOUBLEWORD, pAddr, vAddr, DATA)$ COPzLD (rt, mem)

Exceptions:

- TLB refill exception
- TLB invalid exception
- Bus error exception
- Address error exception
- Coprocessor unusable exception

Opcode Bit Encoding:

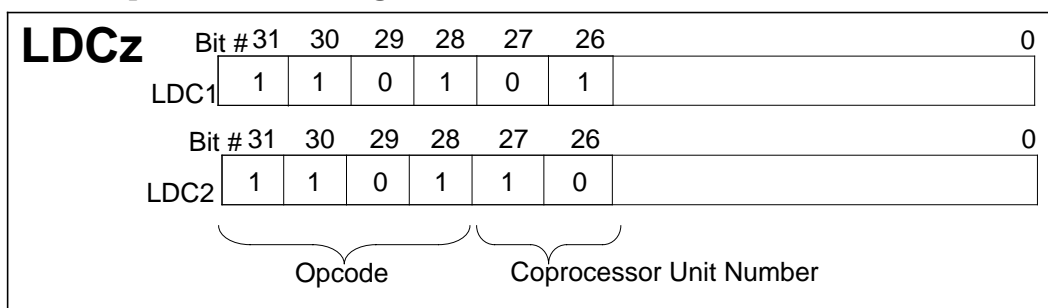

LDL Load Doubleword Left LDL

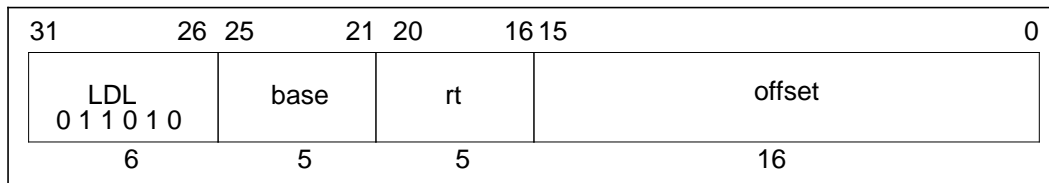
**Format:**

LDL rt, offset(base)

Description:

This instruction can be used in combination with the LDR instruction to load a register with eight consecutive bytes from memory, when the bytes cross a doubleword boundary. LDL loads the left portion of the register with the appropriate part of the high-order doubleword; LDR loads the right portion of the register with the appropriate part of the low-order doubleword.

The LDL instruction adds its sign-extended 16-bit *offset* to the contents of general register *base* to form a virtual address which can specify an arbitrary byte. It reads bytes only from the doubleword in memory which contains the specified starting byte. From one to eight bytes will be loaded, depending on the starting byte specified.

Conceptually, it starts at the specified byte in memory and loads that byte into the high-order (left-most) byte of the register; then it loads bytes from memory into the register until it reaches the low-order byte of the doubleword in memory. The least-significant (right-most) byte(s) of the register will not be changed.

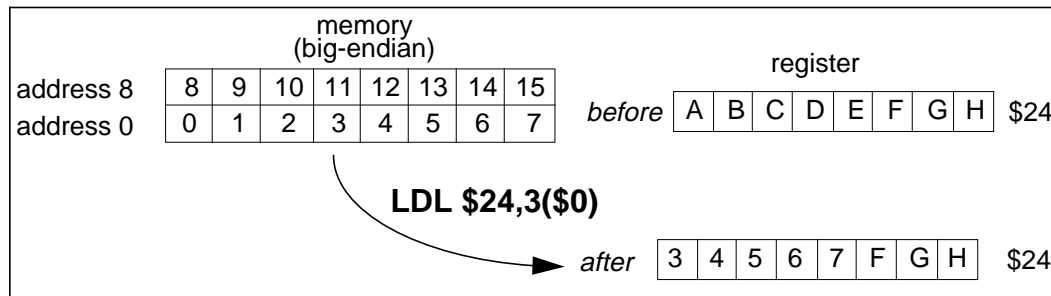

LDL**Load Doubleword Left
(continued)****LDL**

The contents of general register *rt* are internally bypassed within the processor so that no NOP is needed between an immediately preceding load instruction which specifies register *rt* and a following LDL (or LDR) instruction which also specifies register *rt*.

No address exceptions due to alignment are possible.

This operation is only defined for the R4000 operating in 64-bit mode. Execution of this instruction in 32-bit mode causes a reserved instruction exception.

Operation:

```

64  T:  vAddr ← ((offset15)48 || offset15...0) + GPR[base]
      (pAddr, uncached) ← AddressTranslation (vAddr, DATA)
      pAddr ← pAddrPSIZE-1...3 || (pAddr2...0 xor ReverseEndian3)
      if BigEndianMem = 0 then
          pAddr ← pAddrPSIZE-1...3 || 03
      endif
      byte ← vAddr2...0 xor BigEndianCPU3
      mem ← LoadMemory (uncached, byte, pAddr, vAddr, DATA)
      GPR[rt] ← mem7+8*byte...0 || GPR[rt]55-8*byte...0

```

LDL**Load Doubleword Left
(continued)****LDL**

Given a doubleword in a register and a doubleword in memory, the operation of LDL is as follows:

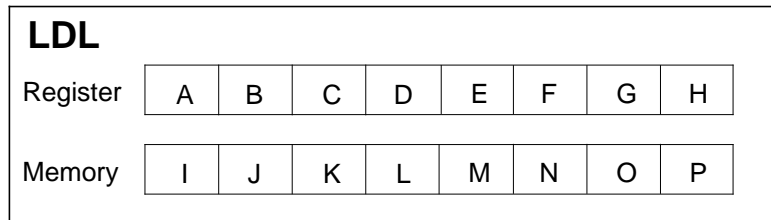

vAddr _{2..0}	BigEndianCPU = 0			BigEndianCPU = 1				
	destination	type	offset		destination	type	offset	
			LEM	BEM			LEM	BEM
0	P B C D E F G H	0	0	7	I J K L M N O P	7	0	0
1	O P C D E F G H	1	0	6	J K L M N O P H	6	0	1
2	N O P D E F G H	2	0	5	K L M N O P G H	5	0	2
3	M N O P E F G P	3	0	4	L M N O P F G H	4	0	3
4	L M N O P F G H	4	0	3	M N O P E F G H	3	0	4
5	K L M N O P G H	5	0	2	N O P D E F G H	2	0	5
6	J K L M N O P H	6	0	1	O P C D E F G H	1	0	6
7	I J K L M N O P	7	0	0	P B C D E F G H	0	0	7

LEM Little-endian memory (BigEndianMem = 0)

BEM BigEndianMem = 1

Type AccessType (see Table 2-1) sent to memory

Offset pAddr_{2..0} sent to memory

Exceptions:

TLB refill exception

TLB invalid exception

Bus error exception

Address error exception

Reserved instruction exception (R4000 in 32-bit mode)

LDR

Load Doubleword Right

LDR

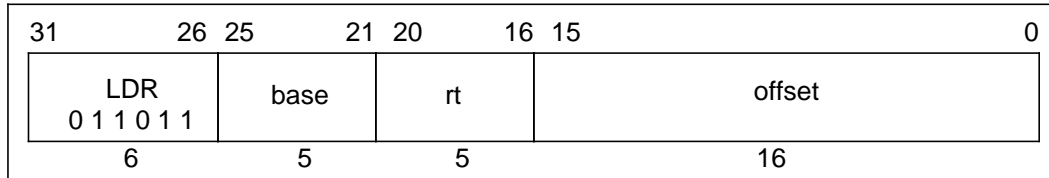
**Format:**

LDR rt, offset(base)

Description:

This instruction can be used in combination with the LDL instruction to load a register with eight consecutive bytes from memory, when the bytes cross a doubleword boundary. LDR loads the right portion of the register with the appropriate part of the low-order doubleword; LDL loads the left portion of the register with the appropriate part of the high-order doubleword.

The LDR instruction adds its sign-extended 16-bit *offset* to the contents of general register *base* to form a virtual address which can specify an arbitrary byte. It reads bytes only from the doubleword in memory which contains the specified starting byte. From one to eight bytes will be loaded, depending on the starting byte specified.

Conceptually, it starts at the specified byte in memory and loads that byte into the low-order (right-most) byte of the register; then it loads bytes from memory into the register until it reaches the high-order byte of the doubleword in memory. The most significant (left-most) byte(s) of the register will not be changed.

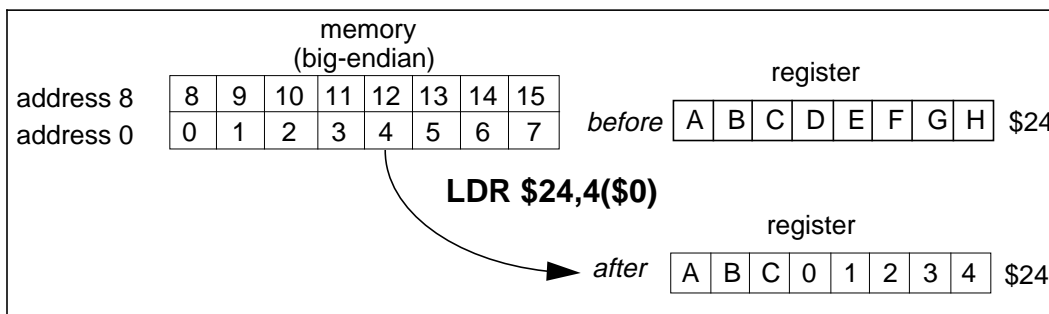

LDR**Load Doubleword Right
(continued)****LDR**

The contents of general register *rt* are internally bypassed within the processor so that no NOP is needed between an immediately preceding load instruction which specifies register *rt* and a following LDR (or LDL) instruction which also specifies register *rt*.

No address exceptions due to alignment are possible.

This operation is only defined for the R4000 operating in 64-bit mode. Execution of this instruction in 32-bit mode causes a reserved instruction exception.

Operation:

```

64  T:  vAddr ← ((offset15)48 || offset15...0) + GPR[base]
      (pAddr, uncached) ← AddressTranslation (vAddr, DATA)
      pAddr ← pAddrPSIZE-1...3 || (pAddr2...0 xor ReverseEndian3)
      if BigEndianMem = 1 then
        pAddr ← pAddr31...3 || 03
      endif
      byte ← vAddr2...0 xor BigEndianCPU3
      mem ← LoadMemory (uncached, byte, pAddr, vAddr, DATA)
      GPR[rt] ← GPR[rt]63...64-8*byte || mem63...8*byte

```

LDR**Load Doubleword Right
(continued)****LDR**

Given a doubleword in a register and a doubleword in memory, the operation of LDR is as follows:

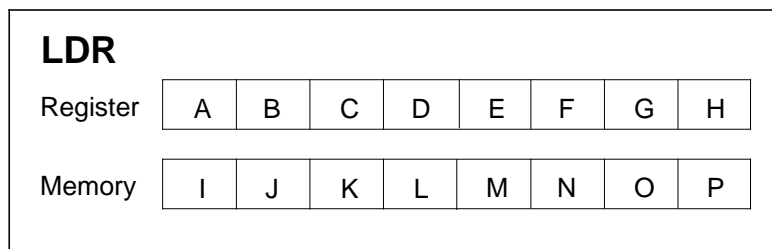

vAddr _{2,0}	BigEndianCPU = 0				BigEndianCPU = 1			
	destination	type	offset		destination	type	offset	
			LEM	BEM			LEM	BEM
0	I J K L M N O P	7	0	0	A B C D E F G I	0	7	0
1	A I J K L M N O	6	1	0	A B C D E F I J	1	6	0
2	A B I J K L M N	5	2	0	A B C D E I J K	2	5	0
3	A B C I J K L M	4	3	0	A B C D I J K L	3	4	0
4	A B C D I J K L	3	4	0	A B C I J K L M	4	3	0
5	A B C D E I J K	2	5	0	A B I J K L M N	5	2	0
6	A B C D E F I J	1	6	0	A I J K L M N O	6	1	0
7	A B C D E F G I	0	7	0	I J K L M N O P	7	0	0

LEM Little-endian memory (BigEndianMem = 0)
BEM BigEndianMem = 1
Type AccessType (see Table 2-1) sent to memory
Offset pAddr_{2...0} sent to memory

Exceptions:

- TLB refill exception
- TLB invalid exception
- Bus error exception
- Address error exception
- Reserved instruction exception (R4000 in 32-bit mode)

LH Load Halfword LH

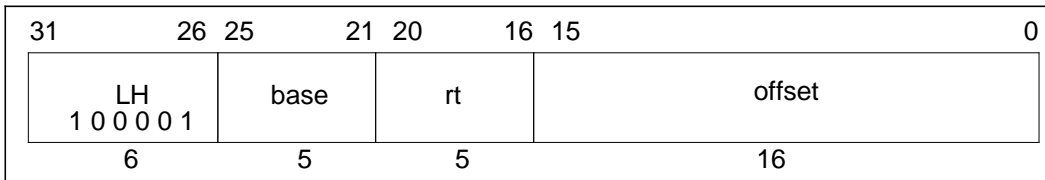
**Format:**LH *rt*, *offset*(*base*)**Description:**

The 16-bit *offset* is sign-extended and added to the contents of general register *base* to form a virtual address. The contents of the halfword at the memory location specified by the effective address are sign-extended and loaded into general register *rt*.

If the least-significant bit of the effective address is non-zero, an address error exception occurs.

Operation:

32	T:	$vAddr \leftarrow ((offset_{15})^{16} \parallel offset_{15..0}) + GPR[base]$ $(pAddr, uncached) \leftarrow AddressTranslation(vAddr, DATA)$ $pAddr \leftarrow pAddr_{PSIZE-1..3} \parallel (pAddr_{2..0} \text{ xor } (ReverseEndian \parallel 0))$ $mem \leftarrow LoadMemory(uncached, HALFWORD, pAddr, vAddr, DATA)$ $byte \leftarrow vAddr_{2..0} \text{ xor } (BigEndianCPU^2 \parallel 0)$ $GPR[rt] \leftarrow (mem_{15+8*byte})^{16} \parallel mem_{15+8*byte..8*byte}$
64	T:	$vAddr \leftarrow ((offset_{15})^{48} \parallel offset_{15..0}) + GPR[base]$ $(pAddr, uncached) \leftarrow AddressTranslation(vAddr, DATA)$ $pAddr \leftarrow pAddr_{PSIZE-1..3} \parallel (pAddr_{2..0} \text{ xor } (ReverseEndian \parallel 0))$ $mem \leftarrow LoadMemory(uncached, HALFWORD, pAddr, vAddr, DATA)$ $byte \leftarrow vAddr_{2..0} \text{ xor } (BigEndianCPU^2 \parallel 0)$ $GPR[rt] \leftarrow (mem_{15+8*byte})^{48} \parallel mem_{15+8*byte..8*byte}$

Exceptions:

- TLB refill exception
- TLB invalid exception
- Bus error exception
- Address error exception

LHU Load Halfword Unsigned LHU

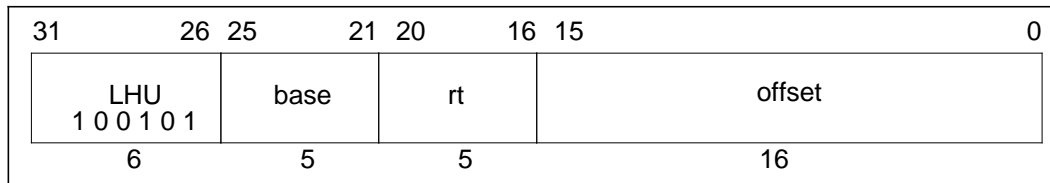
**Format:**

LHU rt, offset(base)

Description:

The 16-bit *offset* is sign-extended and added to the contents of general register *base* to form a virtual address. The contents of the halfword at the memory location specified by the effective address are zero-extended and loaded into general register *rt*.

If the least-significant bit of the effective address is non-zero, an address error exception occurs.

Operation:

32	T:	$vAddr \leftarrow ((offset_{15})^{16} \parallel offset_{15...0}) + GPR[base]$ $(pAddr, uncached) \leftarrow AddressTranslation(vAddr, DATA)$ $pAddr \leftarrow pAddr_{PSIZE-1...3} \parallel (pAddr_{2...0} \text{ xor } (ReverseEndian^2 \parallel 0))$ $mem \leftarrow LoadMemory(uncached, HALFWORD, pAddr, vAddr, DATA)$ $byte \leftarrow vAddr_{2...0} \text{ xor } (BigEndianCPU^2 \parallel 0)$ $GPR[rt] \leftarrow 0^{16} \parallel mem_{15+8*byte...8*byte}$
64	T:	$vAddr \leftarrow ((offset_{15})^{48} \parallel offset_{15...0}) + GPR[base]$ $(pAddr, uncached) \leftarrow AddressTranslation(vAddr, DATA)$ $pAddr \leftarrow pAddr_{PSIZE-1...3} \parallel (pAddr_{2...0} \text{ xor } (ReverseEndian^2 \parallel 0))$ $mem \leftarrow LoadMemory(uncached, HALFWORD, pAddr, vAddr, DATA)$ $byte \leftarrow vAddr_{2...0} \text{ xor } (BigEndianCPU^2 \parallel 0)$ $GPR[rt] \leftarrow 0^{48} \parallel mem_{15+8*byte...8*byte}$

Exceptions:

TLB refill exception
Bus Error exception

TLB invalid exception
Address error exception

LL**Load Linked
(continued)****LL****Operation:**

32	T: $vAddr \leftarrow ((offset_{15})^{16} \parallel offset_{15...0}) + GPR[base]$ $(pAddr, uncached) \leftarrow AddressTranslation(vAddr, DATA)$ $pAddr \leftarrow pAddr_{P_SIZE-1...3} \parallel (pAddr_{2...0} \text{ xor } (ReverseEndian \parallel 0^2))$ $mem \leftarrow LoadMemory(uncached, WORD, pAddr, vAddr, DATA)$ $byte \leftarrow vAddr_{2...0} \text{ xor } (BigEndianCPU \parallel 0^2)$ $GPR[rt] \leftarrow mem_{31+8*byte...8*byte}$ $LLbit \leftarrow 1$
64	T: $vAddr \leftarrow ((offset_{15})^{48} \parallel offset_{15...0}) + GPR[base]$ $(pAddr, uncached) \leftarrow AddressTranslation(vAddr, DATA)$ $pAddr \leftarrow pAddr_{P_SIZE-1...3} \parallel (pAddr_{2...0} \text{ xor } (ReverseEndian \parallel 0^2))$ $mem \leftarrow LoadMemory(uncached, WORD, pAddr, vAddr, DATA)$ $byte \leftarrow vAddr_{2...0} \text{ xor } (BigEndianCPU \parallel 0^2)$ $GPR[rt] \leftarrow (mem_{31+8*byte})^{32} \parallel mem_{31+8*byte...8*byte}$ $LLbit \leftarrow 1$

Exceptions:

- TLB refill exception
- TLB invalid exception
- Bus error exception
- Address error exception

LLD Load Linked Doubleword LLD

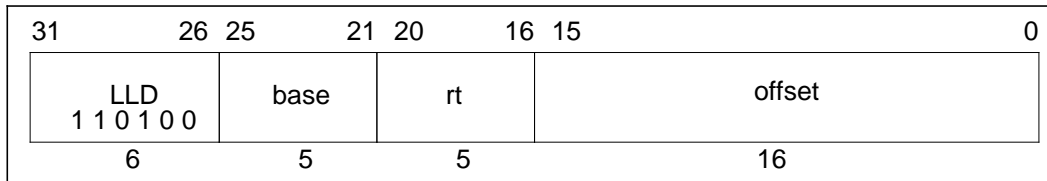
**Format:**LLD *rt*, *offset*(*base*)**Description:**

The 16-bit *offset* is sign-extended and added to the contents of general register *base* to form a virtual address. The contents of the doubleword at the memory location specified by the effective address are loaded into general register *rt*.

The processor begins checking the accessed word for modification by other processor and devices.

Load Linked Doubleword and Store Conditional Doubleword can be used to atomically update memory locations:

L1:	
LLD	T1, (T0)
ADD	T2, T1, 1
SCD	T2, (T0)
BEQ	T2, 0, L1
NOP	

This atomically increments the word addressed by T0. Changing the ADD to an OR changes this to an atomic bit set.

LLD**Load Linked Doubleword
(continued)****LLD**

The operation of LLD is undefined if the addressed location is uncached and, for synchronization between multiple processors, the operation of LLD is undefined if the addressed location is noncoherent. A cache miss that occurs between LLD and SCD may cause SCD to fail, so no load or store operation should occur between LLD and SCD, otherwise the SCD may never be successful. Exceptions also cause SCD to fail, so persistent exceptions must be avoided.

This instruction is available in User mode, and it is not necessary for CP0 to be enabled.

If any of the three least-significant bits of the effective address are non-zero, an address error exception takes place.

This operation is only defined for the R4000 operating in 64-bit mode. Execution of this instruction in 32-bit mode causes a reserved instruction exception.

Operation:

64	T: $vAddr \leftarrow ((offset_{15})^{48} \parallel offset_{15..0}) + GPR[base]$ $(pAddr, uncached) \leftarrow AddressTranslation(vAddr, DATA)$ $mem \leftarrow LoadMemory(uncached, DOUBLEWORD, pAddr, vAddr, DATA)$ $GPR[rt] \leftarrow mem$ $LLbit \leftarrow 1$
----	---

Exceptions:

- TLB refill exception
- TLB invalid exception
- Bus error exception
- Address error exception
- Reserved instruction exception (R4000 in 32-bit mode)

LUI Load Upper Immediate LUI

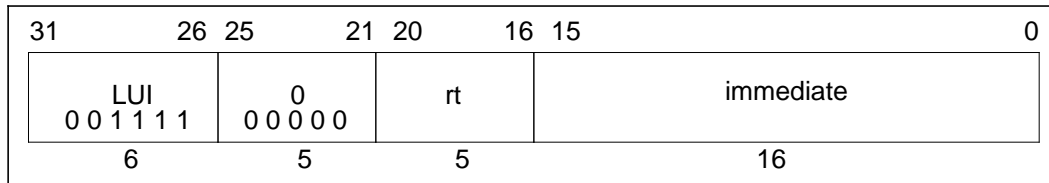
**Format:**

LUI rt, immediate

Description:

The 16-bit *immediate* is shifted left 16 bits and concatenated to 16 bits of zeros. The result is placed into general register *rt*. In 64-bit mode, the loaded word is sign-extended.

Operation:

32	T: GPR[rt] ← immediate 0 ¹⁶
64	T: GPR[rt] ← (immediate ₁₅) ³² immediate 0 ¹⁶

Exceptions:

None

LW Load Word LW

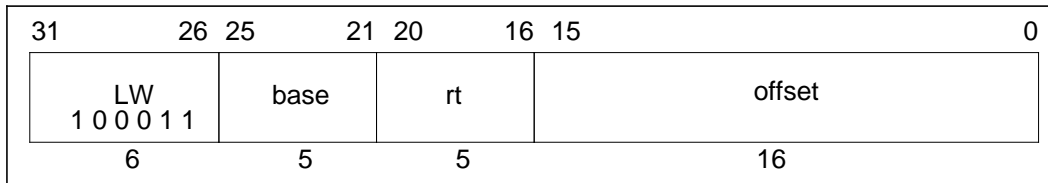
**Format:**

LW rt, offset(base)

Description:

The 16-bit *offset* is sign-extended and added to the contents of general register *base* to form a virtual address. The contents of the word at the memory location specified by the effective address are loaded into general register *rt*. In 64-bit mode, the loaded word is sign-extended. If either of the two least-significant bits of the effective address is non-zero, an address error exception occurs.

Operation:

32	T: $vAddr \leftarrow ((offset_{15})^{16} \parallel offset_{15..0}) + GPR[base]$ $(pAddr, uncached) \leftarrow AddressTranslation(vAddr, DATA)$ $pAddr \leftarrow pAddr_{PSIZE-1..3} \parallel (pAddr_{2..0} \text{ xor } (ReverseEndian \parallel 0^2))$ $mem \leftarrow LoadMemory(uncached, WORD, pAddr, vAddr, DATA)$ $byte \leftarrow vAddr_{2..0} \text{ xor } (BigEndianCPU \parallel 0^2)$ $GPR[rt] \leftarrow mem_{31+8*byte..8*byte}$
64	T: $vAddr \leftarrow ((offset_{15})^{48} \parallel offset_{15..0}) + GPR[base]$ $(pAddr, uncached) \leftarrow AddressTranslation(vAddr, DATA)$ $pAddr \leftarrow pAddr_{PSIZE-1..3} \parallel (pAddr_{2..0} \text{ xor } (ReverseEndian \parallel 0^2))$ $mem \leftarrow LoadMemory(uncached, WORD, pAddr, vAddr, DATA)$ $byte \leftarrow vAddr_{2..0} \text{ xor } (BigEndianCPU \parallel 0^2)$ $GPR[rt] \leftarrow (mem_{31+8*byte})^{32} \parallel mem_{31+8*byte..8*byte}$

Exceptions:

TLB refill exception
Bus error exception

TLB invalid exception
Address error exception

LWCz Load Word To Coprocessor LWCz

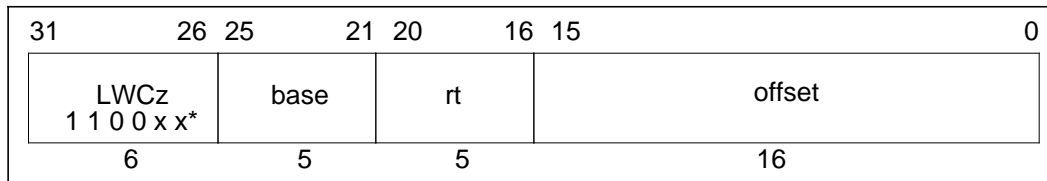
**Format:**

LWCz rt, offset(base)

Description:

The 16-bit *offset* is sign-extended and added to the contents of general register *base* to form a virtual address. The processor reads a word from the addressed memory location, and makes the data available to coprocessor unit *z*.

The manner in which each coprocessor uses the data is defined by the individual coprocessor specifications.

If either of the two least-significant bits of the effective address is non-zero, an address error exception occurs.

This instruction is not valid for use with CP0.

*See the table “Opcode Bit Encoding” on next page, or “CPU Instruction Opcode Bit Encoding” at the end of Appendix A.

LWCz**Load Word To Coprocessor
(continued)****LWCz****Operation:**

32	<p>T: $vAddr \leftarrow ((offset_{15})^{16} \parallel offset_{15...0}) + GPR[base]$ $(pAddr, uncached) \leftarrow AddressTranslation(vAddr, DATA)$ $pAddr \leftarrow pAddr_{PSIZE-1...3} \parallel (pAddr_{2...0} \text{ xor } (ReverseEndian \parallel 0^2))$ $mem \leftarrow LoadMemory(uncached, WORD, pAddr, vAddr, DATA)$ $byte \leftarrow vAddr_{2...0} \text{ xor } (BigEndianCPU \parallel 0^2)$ COPzLW (byte, rt, mem)</p>
64	<p>T: $vAddr \leftarrow ((offset_{15})^{48} \parallel offset_{15...0}) + GPR[base]$ $(pAddr, uncached) \leftarrow AddressTranslation(vAddr, DATA)$ $pAddr \leftarrow pAddr_{PSIZE-1...3} \parallel (pAddr_{2...0} \text{ xor } (ReverseEndian \parallel 0^2))$ $mem \leftarrow LoadMemory(uncached, WORD, pAddr, vAddr, DATA)$ $byte \leftarrow vAddr_{2...0} \text{ xor } (BigEndianCPU \parallel 0^2)$ COPzLW (byte, rt, mem)</p>

Exceptions:

TLB refill exception	TLB invalid exception
Bus error exception	Address error exception
Coprocessor unusable exception	

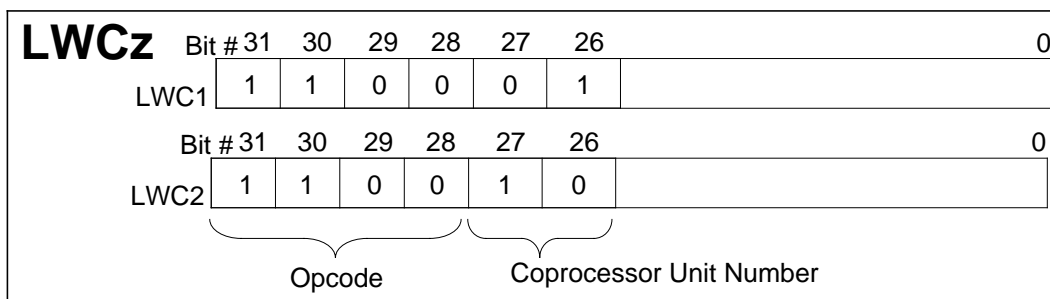
Opcode Bit Encoding:

LWL Load Word Left LWL

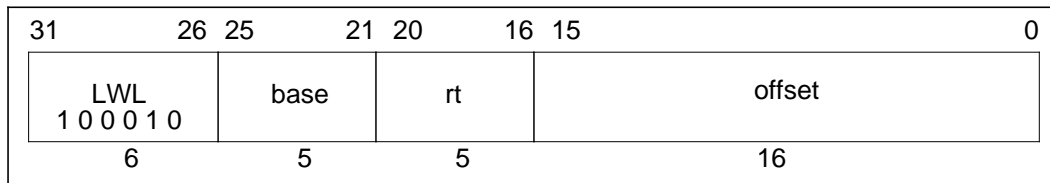
**Format:**

LWL rt, offset(base)

Description:

This instruction can be used in combination with the LWR instruction to load a register with four consecutive bytes from memory, when the bytes cross a word boundary. LWL loads the left portion of the register with the appropriate part of the high-order word; LWR loads the right portion of the register with the appropriate part of the low-order word.

The LWL instruction adds its sign-extended 16-bit *offset* to the contents of general register *base* to form a virtual address which can specify an arbitrary byte. It reads bytes only from the word in memory which contains the specified starting byte. From one to four bytes will be loaded, depending on the starting byte specified. In 64-bit mode, the loaded word is sign-extended.

Conceptually, it starts at the specified byte in memory and loads that byte into the high-order (left-most) byte of the register; then it loads bytes from memory into the register until it reaches the low-order byte of the word in memory. The least-significant (right-most) byte(s) of the register will not be changed.

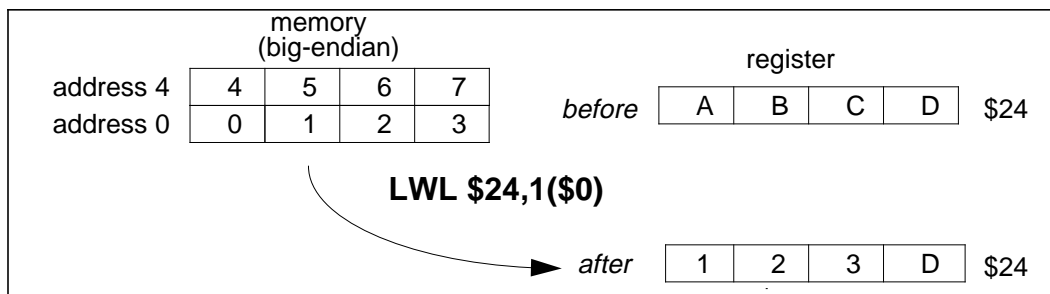

LWL**Load Word Left
(continued)****LWL**

The contents of general register *rt* are internally bypassed within the processor so that no NOP is needed between an immediately preceding load instruction which specifies register *rt* and a following LWL (or LWR) instruction which also specifies register *rt*. No address exceptions due to alignment are possible.

Operation:

```

32  T:  vAddr ← ((offset15)16 || offset15...0) + GPR[base]
      (pAddr, uncached) ← AddressTranslation (vAddr, DATA)
      pAddr ← pAddrPSIZE-1...3 || (pAddr2...0 xor ReverseEndian3)
      if BigEndianMem = 0 then
          pAddr ← pAddrPSIZE-1...2 || 02
      endif
      byte ← vAddr1...0 xor BigEndianCPU2
      word ← vAddr2 xor BigEndianCPU
      mem ← LoadMemory (uncached, 0 || byte, pAddr, vAddr, DATA)
      temp ← mem32*word+8*byte+7...32*word || GPR[rt]23-8*byte...0
      GPR[rt] ← temp

64  T:  vAddr ← ((offset15)48 || offset15...0) + GPR[base]
      (pAddr, uncached) ← AddressTranslation (vAddr, DATA)
      pAddr ← pAddrPSIZE-1...3 || (pAddr2...0 xor ReverseEndian3)
      if BigEndianMem = 0 then
          pAddr ← pAddrPSIZE-1...2 || 02
      endif
      byte ← vAddr1...0 xor BigEndianCPU2
      word ← vAddr2 xor BigEndianCPU
      mem ← LoadMemory (uncached, 0 || byte, pAddr, vAddr, DATA)
      temp ← mem32*word+8*byte+7...32*word || GPR[rt]23-8*byte...0
      GPR[rt] ← (temp31)32 || temp

```

LWL**Load Word Left
(continued)****LWL**

Given a doubleword in a register and a doubleword in memory, the operation of LWL is as follows:

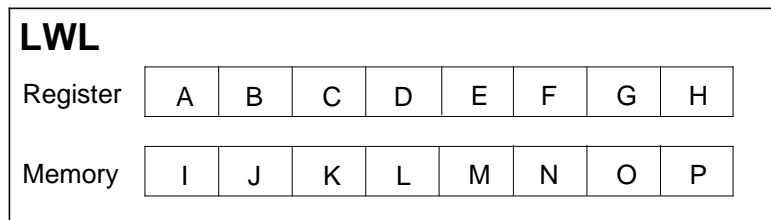

vAddr _{2..0}	BigEndianCPU = 0				BigEndianCPU = 1			
	destination	type	offset		destination	type	offset	
			LEM	BEM			LEM	BEM
0	S S S S P F G H	0	0	7	S S S S I J K L	3	4	0
1	S S S S O P G H	1	0	6	S S S S J K L H	2	4	1
2	S S S S N O P H	2	0	5	S S S S K L G H	1	4	2
3	S S S S M N O P	3	0	4	S S S S L F G H	0	4	3
4	S S S S L F G H	0	4	3	S S S S M N O P	3	0	4
5	S S S S K L G H	1	4	2	S S S S N O P H	2	0	5
6	S S S S J K L H	2	4	1	S S S S O P G H	1	0	6
7	S S S S I J K L	3	4	0	S S S S P F G H	0	0	7

LEM Little-endian memory (BigEndianMem = 0)
BEM BigEndianMem = 1
Type AccessType (see Table 2-1) sent to memory
Offset pAddr_{2..0} sent to memory
S sign-extend of destination₃₁

Exceptions:

TLB refill exception
 TLB invalid exception
 Bus error exception
 Address error exception

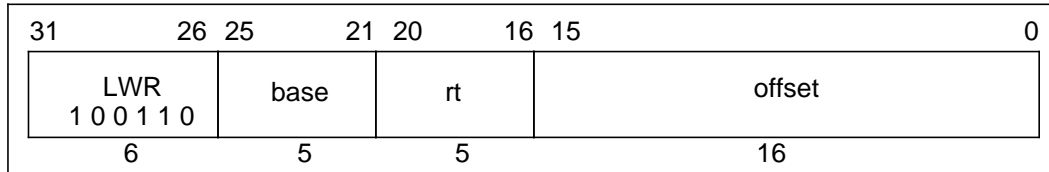
LWR**Load Word Right****LWR****Format:**

LWR rt, offset(base)

Description:

This instruction can be used in combination with the LWL instruction to load a register with four consecutive bytes from memory, when the bytes cross a word boundary. LWR loads the right portion of the register with the appropriate part of the low-order word; LWL loads the left portion of the register with the appropriate part of the high-order word.

The LWR instruction adds its sign-extended 16-bit *offset* to the contents of general register *base* to form a virtual address which can specify an arbitrary byte. It reads bytes only from the word in memory which contains the specified starting byte. From one to four bytes will be loaded, depending on the starting byte specified. In 64-bit mode, if bit 31 of the destination register is loaded, then the loaded word is sign-extended.

Conceptually, it starts at the specified byte in memory and loads that byte into the low-order (right-most) byte of the register; then it loads bytes from memory into the register until it reaches the high-order byte of the word in memory. The most significant (left-most) byte(s) of the register will not be changed.

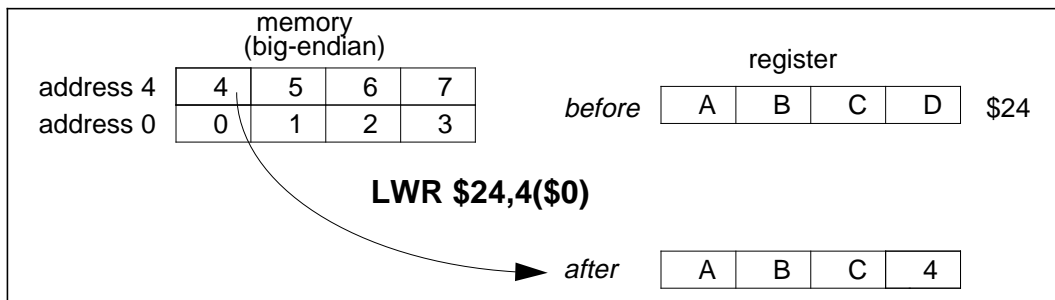

LWR**Load Word Right
(continued)****LWR**

The contents of general register *rt* are internally bypassed within the processor so that no NOP is needed between an immediately preceding load instruction which specifies register *rt* and a following LWR (or LWL) instruction which also specifies register *rt*. No address exceptions due to alignment are possible.

Operation:

```

32  T:  vAddr ← ((offset15)16 || offset15...0) + GPR[base]
      (pAddr, uncached) ← AddressTranslation (vAddr, DATA)
      pAddr ← pAddrPSIZE-1...3 || (pAddr2...0 xor ReverseEndian3)
      if BigEndianMem = 1 then
          pAddr ← pAddrPSIZE-31...3 || 03
      endif
      byte ← vAddr1...0 xor BigEndianCPU2
      word ← vAddr2 xor BigEndianCPU
      mem ← LoadMemory (uncached, 0 || byte, pAddr, vAddr, DATA)
      temp ← GPR[rt]31...32-8*byte || mem31+32*word...32*word+8*byte
      GPR[rt] ← temp

64  T:  vAddr ← ((offset15)48 || offset15...0) + GPR[base]
      (pAddr, uncached) ← AddressTranslation (vAddr, DATA)
      pAddr ← pAddrPSIZE-1...3 || (pAddr2...0 xor ReverseEndian3)
      if BigEndianMem = 1 then
          pAddr ← pAddrPSIZE-31...3 || 03
      endif
      byte ← vAddr1...0 xor BigEndianCPU2
      word ← vAddr2 xor BigEndianCPU
      mem ← LoadMemory (uncached, 0 || byte, pAddr, vAddr, DATA)
      temp ← GPR[rt]31...32-8*byte || mem31+32*word...32*word+8*byte
      GPR[rt] ← (temp31)32 || temp

```

LWR

Load Word Right (continued)

LWR

Given a word in a register and a word in memory, the operation of LWR is as follows:

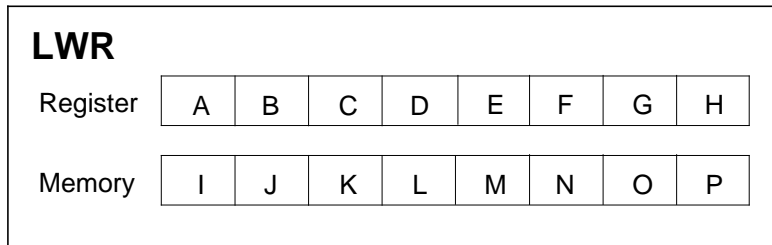

vAddr _{2..0}	BigEndianCPU = 0				BigEndianCPU = 1			
	destination	type	offset		destination	type	offset	
			LEM	BEM			LEM	BEM
0	S S S S M N O P	0	0	4	X X X X E F G I	0	7	0
1	X X X X E M N O	1	1	4	X X X X E F I J	1	6	0
2	X X X X E F M N	2	2	4	X X X X E I J K	2	5	0
3	X X X X E F G M	3	3	4	S S S S I J K L	3	4	0
4	S S S S I J K L	0	4	0	X X X X E F G M	0	3	4
5	X X X X E I J K	1	5	0	X X X X E F M N	1	2	4
6	X X X X E F I J	2	6	0	X X X X E M N O	2	1	4
7	X X X X E F G I	3	7	0	S S S S M N O P	3	0	4

- LEM* Little-endian memory (BigEndianMem = 0)
- BEM* BigEndianMem = 1
- Type* AccessType (see Table 2-1) sent to memory
- Offset* pAddr_{2...0} sent to memory
- S* sign-extend of destination₃₁
- X* either unchanged or sign-extend of destination₃₁

Exceptions:

- TLB refill exception
- TLB invalid exception
- Bus error exception
- Address error exception

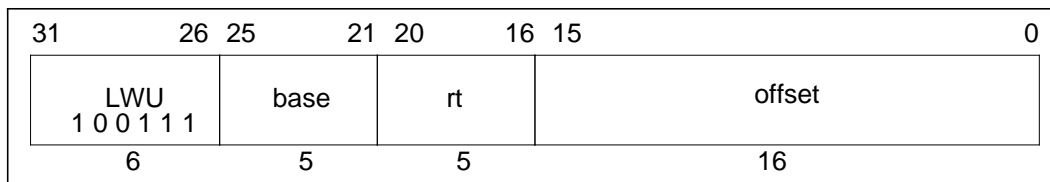
LWU**Load Word Unsigned****LWU****Format:**

LWU rt, offset(base)

Description:

The 16-bit *offset* is sign-extended and added to the contents of general register *base* to form a virtual address. The contents of the word at the memory location specified by the effective address are loaded into general register *rt*. The loaded word is zero-extended.

If either of the two least-significant bits of the effective address is non-zero, an address error exception occurs.

This operation is only defined for the R4000 operating in 64-bit mode. Execution of this instruction in 32-bit mode causes a reserved instruction exception.

Operation:

```

64  T:  vAddr ← ((offset15)48 || offset15...0) + GPR[base]
      (pAddr, uncached) ← AddressTranslation (vAddr, DATA)
      pAddr ← pAddrPSIZE-1...3 || (pAddr2...0 xor (ReverseEndian || 02))
      mem ← LoadMemory (uncached, WORD, pAddr, vAddr, DATA)
      byte ← vAddr2...0 xor (BigEndianCPU || 02)
      GPR[rt] ← 032 || mem31+8*byte...8*byte

```

Exceptions:

- TLB refill exception
- TLB invalid exception
- Bus error exception
- Address error exception
- Reserved instruction exception (R4000 in 32-bit mode)

MFC0 Move From MFC0

System Control Coprocessor

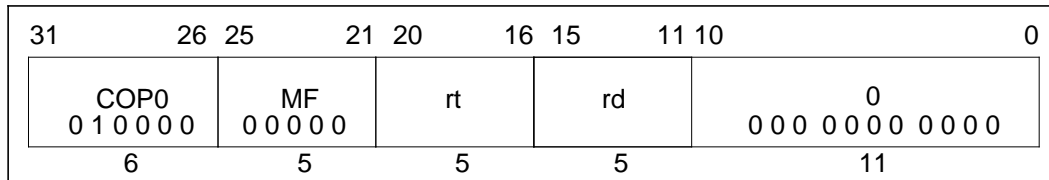
**Format:**

MFC0 rt, rd

Description:

The contents of coprocessor register *rd* of the CP0 are loaded into general register *rt*.

Operation:

32	T: data ← CPR[0,rd]
	T+1: GPR[rt] ← data
64	T: data ← CPR[0,rd]
	T+1: GPR[rt] ← (data ₃₁) ³² data _{31...0}

Exceptions:

Coprocessor unusable exception

MFCz Move From Coprocessor MFCz

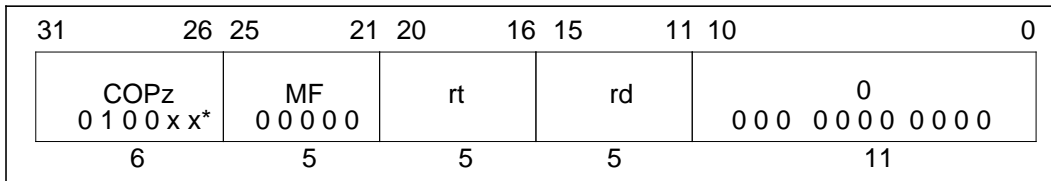
**Format:**

MFCz rt, rd

Description:

The contents of coprocessor register *rd* of coprocessor *z* are loaded into general register *rt*.

Operation:

32	T: data ← CPR[z,rd]
	T+1: GPR[rt] ← data
64	T: if rd ₀ = 0 then
	data ← CPR[z,rd _{4...1} 0] _{31...0}
	else
	data ← CPR[z,rd _{4...1} 0] _{63...32}
	endif
	T+1: GPR[rt] ← (data ₃₁) ³² data

Exceptions:

Coprocessor unusable exception

*See the table “Opcode Bit Encoding” on next page, or “CPU Instruction Opcode Bit Encoding” at the end of Appendix A.

MFCz Move From Coprocessor MFCz

(continued)

Opcode Bit Encoding:

MFCz	Bit #	31	30	29	28	27	26	25	24	23	22	21	0
	MFC0	0	1	0	0	0	0	0	0	0	0	0	
	Bit #	31	30	29	28	27	26	25	24	23	22	21	0
MFC1	0	1	0	0	0	1	0	0	0	0	0	0	
Bit #	31	30	29	28	27	26	25	24	23	22	21	0	
MFC2	0	1	0	0	1	0	0	0	0	0	0	0	

Opcode
Coprocessor Suboperation
 Coprocessor Unit Number

MFHI Move From HI MFHI

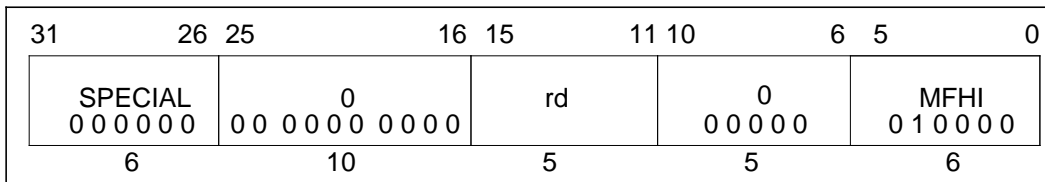
**Format:**

MFHI rd

Description:

The contents of special register *HI* are loaded into general register *rd*.

To ensure proper operation in the event of interruptions, the two instructions which follow a MFHI instruction may not be any of the instructions which modify the *HI* register: MULT, MULTU, DIV, DIVU, MTHI, DMULT, DMULTU, DDIV, DDIVU.

Operation:

32, 64 T: GPR[rd] ← HI

Exceptions:

None

MFLO Move From Lo MFLO

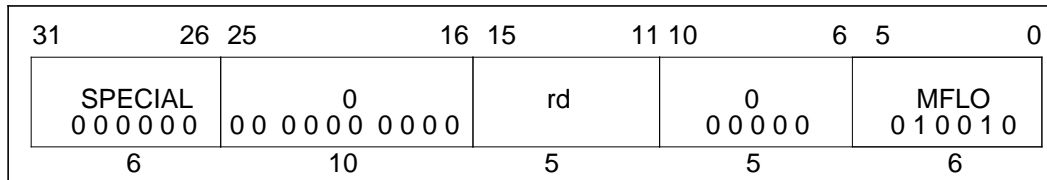
**Format:**

MFLO rd

Description:

The contents of special register *LO* are loaded into general register *rd*.

To ensure proper operation in the event of interruptions, the two instructions which follow a MFLO instruction may not be any of the instructions which modify the *LO* register: MULT, MULTU, DIV, DIVU, MTLO, DMULT, DMULTU, DDIV, DDIVU.

Operation:

32, 64 T: GPR[rd] ← LO

Exceptions:

None

MTC0 Move To MTC0

System Control Coprocessor

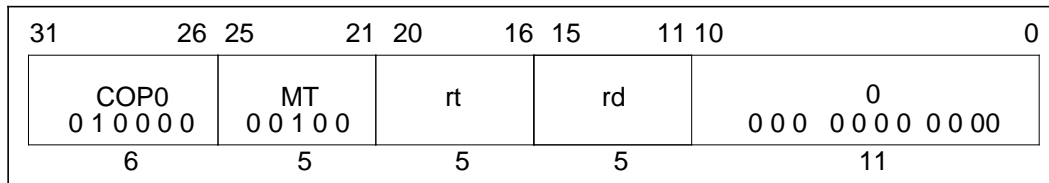
**Format:**

MTC0 rt, rd

Description:

The contents of general register *rt* are loaded into coprocessor register *rd* of CP0.

Because the state of the virtual address translation system may be altered by this instruction, the operation of load instructions, store instructions, and TLB operations immediately prior to and after this instruction are undefined.

Operation:

32, 64	T:	$data \leftarrow GPR[rt]$
	T+1:	$CPR[0,rd] \leftarrow data$

Exceptions:

Coprocessor unusable exception

MTLO Move To LO MTLO

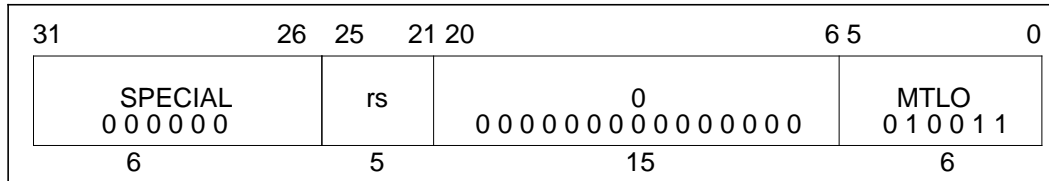
**Format:**

MTLO rs

Description:

The contents of general register *rs* are loaded into special register *LO*.

If a MTLO operation is executed following a MULT, MULTU, DIV, or DIVU instruction, but before any MFLO, MFHI, MTLO, or MTHI instructions, the contents of special register *HI* are undefined.

Operation:

32,64	T-2: LO ← undefined
	T-1: LO ← undefined
	T: LO ← GPR[rs]

Exceptions:

None

MULT Multiply MULT

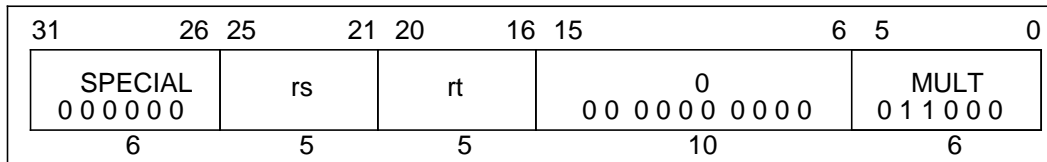
**Format:**

MULT rs, rt

Description:

The contents of general registers *rs* and *rt* are multiplied, treating both operands as 32-bit 2's complement values. No integer overflow exception occurs under any circumstances. In 64-bit mode, the operands must be valid 32-bit, sign-extended values.

When the operation completes, the low-order word of the double result is loaded into special register *LO*, and the high-order word of the double result is loaded into special register *HI*.

If either of the two preceding instructions is MFHI or MFLO, the results of these instructions are undefined. Correct operation requires separating reads of *HI* or *LO* from writes by a minimum of two other instructions.

MULT**Multiply
(continued)****MULT****Operation:**

32	T-2:	LO	← undefined
		HI	← undefined
	T-1:	LO	← undefined
		HI	← undefined
	T:	t	← GPR[rs] * GPR[rt]
		LO	← $t_{31...0}$
HI		← $t_{63...32}$	
64	T-2:	LO	← undefined
		HI	← undefined
	T-1:	LO	← undefined
		HI	← undefined
	T:	t	← GPR[rs] _{31...0} * GPR[rt] _{31...0}
		LO	← $(t_{31})^{32} \parallel t_{31...0}$
HI		← $(t_{63})^{32} \parallel t_{63...32}$	

Exceptions:

None

MULTU Multiply Unsigned MULTU

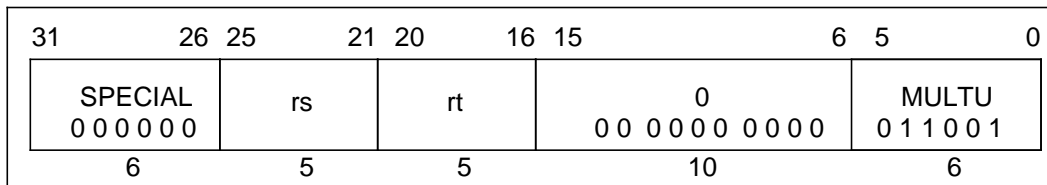
**Format:**

MULTU rs, rt

Description:

The contents of general register *rs* and the contents of general register *rt* are multiplied, treating both operands as unsigned values. No overflow exception occurs under any circumstances. In 64-bit mode, the operands must be valid 32-bit, sign-extended values.

When the operation completes, the low-order word of the double result is loaded into special register *LO*, and the high-order word of the double result is loaded into special register *HI*.

If either of the two preceding instructions is MFHI or MFLO, the results of these instructions are undefined. Correct operation requires separating reads of *HI* or *LO* from writes by a minimum of two instructions.

MULTU**Multiply Unsigned
(continued)****MULTU****Operation:**

32	T-2:	LO	← undefined
		HI	← undefined
	T-1:	LO	← undefined
		HI	← undefined
	T:	t	← (0 GPR[rs]) * (0 GPR[rt])
		LO	← $t_{31...0}$
		HI	← $t_{63...32}$
64	T-2:	LO	← undefined
		HI	← undefined
	T-1:	LO	← undefined
		HI	← undefined
	T:	t	← (0 GPR[rs] _{31...0}) * (0 GPR[rt] _{31...0})
		LO	← $(t_{31})^{32} t_{31...0}$
		HI	← $(t_{63})^{32} t_{63...32}$

Exceptions:

None

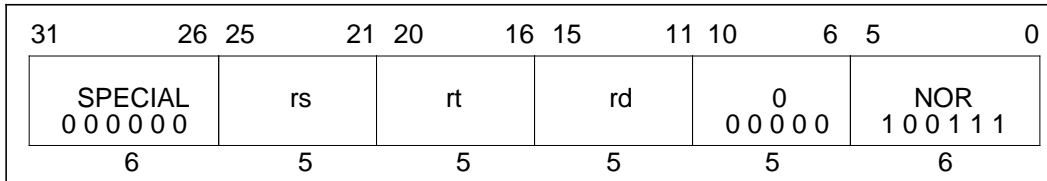
NOR**Nor****NOR****Format:**

NOR rd, rs, rt

Description:

The contents of general register *rs* are combined with the contents of general register *rt* in a bit-wise logical NOR operation. The result is placed into general register *rd*.

Operation:

$$32, 64 \quad T: \quad \text{GPR}[rd] \leftarrow \text{GPR}[rs] \text{ nor } \text{GPR}[rt]$$
Exceptions:

None

OR Or OR

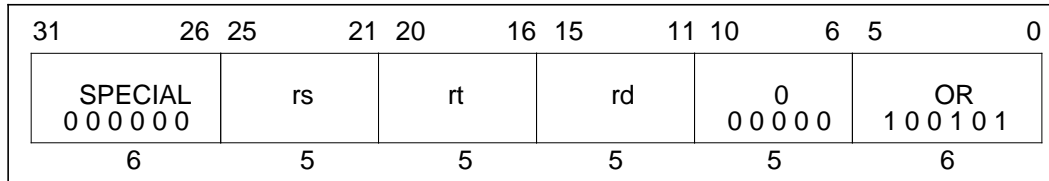
**Format:**

OR rd, rs, rt

Description:

The contents of general register *rs* are combined with the contents of general register *rt* in a bit-wise logical OR operation. The result is placed into general register *rd*.

Operation:

32, 64	T: GPR[rd] ← GPR[rs] or GPR[rt]
--------	---------------------------------

Exceptions:

None

ORI Or Immediate ORI

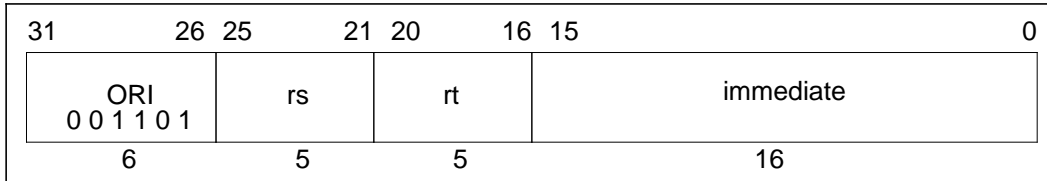
**Format:**ORI *rt*, *rs*, *immediate***Description:**

The 16-bit *immediate* is zero-extended and combined with the contents of general register *rs* in a bit-wise logical OR operation. The result is placed into general register *rt*.

Operation:

32	T: GPR[<i>rt</i>] ← GPR[<i>rs</i>] _{31...16} (immediate or GPR[<i>rs</i>] _{15...0})
64	T: GPR[<i>rt</i>] ← GPR[<i>rs</i>] _{63...16} (immediate or GPR[<i>rs</i>] _{15...0})

Exceptions:

None

SB Store Byte SB

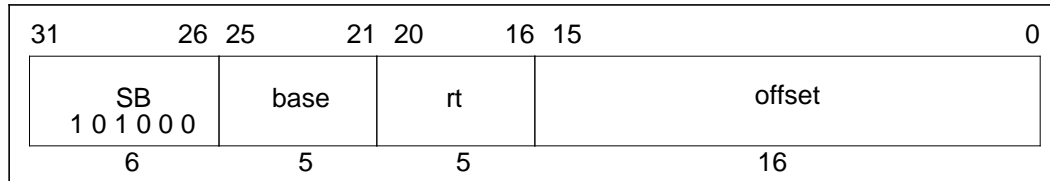
**Format:**

SB rt, offset(base)

Description:

The 16-bit *offset* is sign-extended and added to the contents of general register *base* to form a virtual address. The least-significant byte of register *rt* is stored at the effective address.

Operation:

32	T: $vAddr \leftarrow ((offset_{15})^{16} \parallel offset_{15..0}) + GPR[base]$ $(pAddr, uncached) \leftarrow AddressTranslation(vAddr, DATA)$ $pAddr \leftarrow pAddr_{P_{SIZE}-1..3} \parallel (pAddr_{2..0} \text{ xor } ReverseEndian^3)$ $byte \leftarrow vAddr_{2..0} \text{ xor } BigEndianCPU^3$ $data \leftarrow GPR[rt]_{63-8*byte..0} \parallel 0^{8*byte}$ StoreMemory(uncached, BYTE, data, pAddr, vAddr, DATA)
64	T: $vAddr \leftarrow ((offset_{15})^{48} \parallel offset_{15..0}) + GPR[base]$ $(pAddr, uncached) \leftarrow AddressTranslation(vAddr, DATA)$ $pAddr \leftarrow pAddr_{P_{SIZE}-1..3} \parallel (pAddr_{2..0} \text{ xor } ReverseEndian^3)$ $byte \leftarrow vAddr_{2..0} \text{ xor } BigEndianCPU^3$ $data \leftarrow GPR[rt]_{63-8*byte..0} \parallel 0^{8*byte}$ StoreMemory(uncached, BYTE, data, pAddr, vAddr, DATA)

Exceptions:

- TLB refill exception
- TLB invalid exception
- TLB modification exception
- Bus error exception
- Address error exception

SC Store Conditional SC

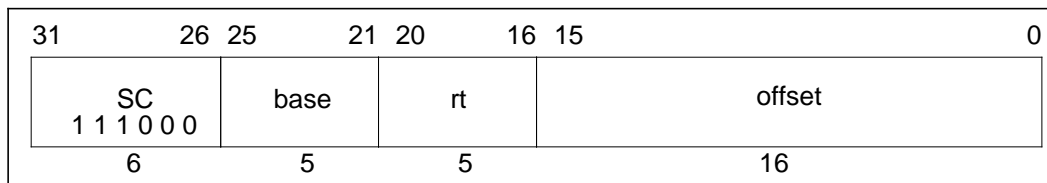
**Format:**

SC rt, offset(base)

Description:

The 16-bit offset is sign-extended and added to the contents of general register *base* to form a virtual address. The contents of general register *rt* are conditionally stored at the memory location specified by the effective address.

If any other processor or device has modified the physical address since the time of the previous Load Linked instruction, or if an ERET instruction occurs between the Load Linked instruction and this store instruction, the store fails and is inhibited from taking place.

The success or failure of the store operation (as defined above) is indicated by the contents of general register *rt* after execution of the instruction. A successful store sets the contents of general register *rt* to 1; an unsuccessful store sets it to 0.

The operation of Store Conditional is undefined when the address is different from the address used in the last Load Linked.

This instruction is available in User mode; it is not necessary for CP0 to be enabled.

If either of the two least-significant bits of the effective address is non-zero, an address error exception takes place.

If this instruction should both fail and take an exception, the exception takes precedence.

SC**Store Conditional
(continued)****SC****Operation:**

```

32  T:  vAddr ← ((offset15)16 || offset15...0) + GPR[base]
      (pAddr, uncached) ← AddressTranslation (vAddr, DATA)
      pAddr ← pAddrPSIZE-1...3 || (pAddr2...0 xor (ReverseEndian || 02))
      data ← GPR[rt]63-8*byte...0 || 08*byte
      if LLbit then
        StoreMemory (uncached, WORD, data, pAddr, vAddr, DATA)
      endif
      GPR[rt] ← 031 || LLbit

64  T:  vAddr ← ((offset15)48 || offset15...0) + GPR[base]
      (pAddr, uncached) ← AddressTranslation (vAddr, DATA)
      pAddr ← pAddrPSIZE-1...3 || (pAddr2...0 xor (ReverseEndian || 02))
      data ← GPR[rt]63-8*byte...0 || 08*byte
      if LLbit then
        StoreMemory (uncached, WORD, data, pAddr, vAddr, DATA)
      endif
      GPR[rt] ← 063 || LLbit

```

Exceptions:

- TLB refill exception
- TLB invalid exception
- TLB modification exception
- Bus error exception
- Address error exception

SCD**Store Conditional Doubleword
(continued)****SCD**

If this instruction should both fail and take an exception, the exception takes precedence.

This operation is only defined for the R4000 operating in 64-bit mode. Execution of this instruction in 32-bit mode causes a reserved instruction exception.

Operation:

```

64  T:  vAddr ← ((offset15)48 || offset15..0) + GPR[base]
      (pAddr, uncached) ← AddressTranslation (vAddr, DATA)
      data ← GPR[rt]
      if LLbit then
          StoreMemory (uncached, DOUBLEWORD, data, pAddr, vAddr, DATA)
      endif
      GPR[rt] ← 063 || LLbit

```

Exceptions:

- TLB refill exception
- TLB invalid exception
- TLB modification exception
- Bus error exception
- Address error exception
- Reserved instruction exception (R4000 in 32-bit mode)

SD Store Doubleword SD

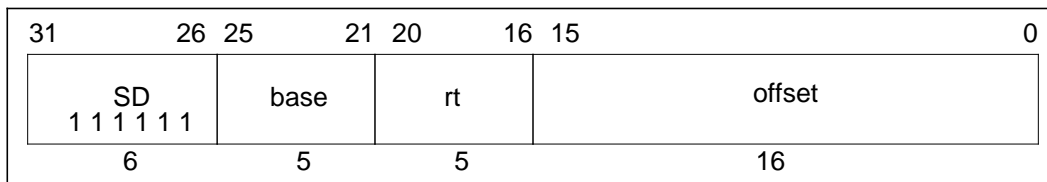
**Format:**

SD rt, offset(base)

Description:

The 16-bit *offset* is sign-extended and added to the contents of general register *base* to form a virtual address. The contents of general register *rt* are stored at the memory location specified by the effective address.

If either of the three least-significant bits of the effective address are non-zero, an address error exception occurs.

This operation is only defined for the R4000 operating in 64-bit mode. Execution of this instruction in 32-bit mode causes a reserved instruction exception.

Operation:

64 T: $vAddr \leftarrow ((offset_{15})^{48} \parallel offset_{15..0}) + GPR[base]$
 $(pAddr, uncached) \leftarrow AddressTranslation(vAddr, DATA)$
 $data \leftarrow GPR[rt]$
 StoreMemory (uncached, DOUBLEWORD, data, pAddr, vAddr, DATA)

Exceptions:

- TLB refill exception
- TLB invalid exception
- TLB modification exception
- Bus error exception
- Address error exception
- Reserved instruction exception (R4000 in 32-bit user mode
R4000 in 32-bit supervisor mode)

SDCz Store Doubleword From Coprocessor SDCz

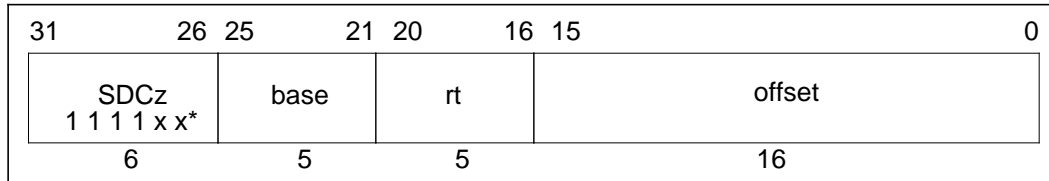
**Format:**

SDCz rt, offset(base)

Description:

The 16-bit *offset* is sign-extended and added to the contents of general register *base* to form a virtual address. Coprocessor unit *z* sources a doubleword, which the processor writes to the addressed memory location. The data to be stored is defined by individual coprocessor specifications.

If any of the three least-significant bits of the effective address are non-zero, an address error exception takes place.

This instruction is not valid for use with CP0.

This instruction is undefined when the least-significant bit of the *rt* field is non-zero.

Operation:

32	T: $vAddr \leftarrow ((offset_{15})^{16} \parallel offset_{15...0}) + GPR[base]$ $(pAddr, uncached) \leftarrow AddressTranslation(vAddr, DATA)$ $data \leftarrow COPzSD(rt),$ StoreMemory (uncached, DOUBLEWORD, data, pAddr, vAddr, DATA)
64	T: $vAddr \leftarrow ((offset_{15})^{48} \parallel offset_{15...0}) + GPR[base]$ $(pAddr, uncached) \leftarrow AddressTranslation(vAddr, DATA)$ $data \leftarrow COPzSD(rt),$ StoreMemory (uncached, DOUBLEWORD, data, pAddr, vAddr, DATA)

*See the table, "Opcode Bit Encoding" on next page, or "CPU Instruction Opcode Bit Encoding" at the end of Appendix A.

SDCz

Store Doubleword From Coprocessor (continued)

SDCz

Exceptions:

- TLB refill exception
- TLB invalid exception
- TLB modification exception
- Bus error exception
- Address error exception
- Coprocessor unusable exception

Opcode Bit Encoding:

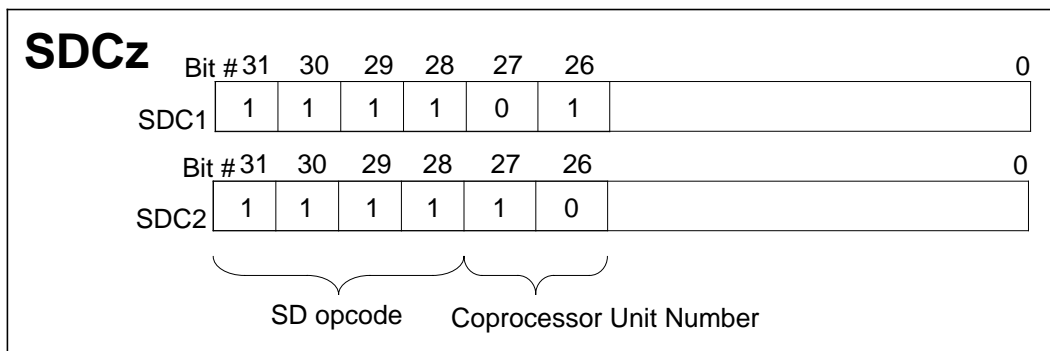

SDL Store Doubleword Left SDL

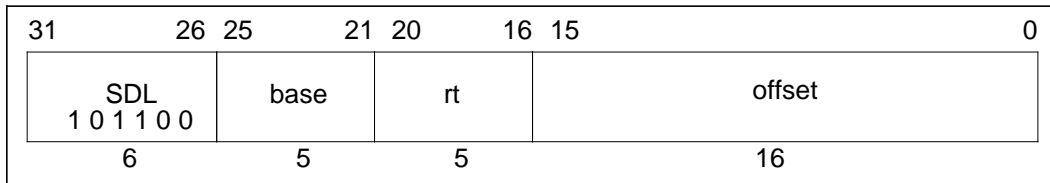
**Format:**

SDL rt, offset(base)

Description:

This instruction can be used with the SDR instruction to store the contents of a register into eight consecutive bytes of memory, when the bytes cross a doubleword boundary. SDL stores the left portion of the register into the appropriate part of the high-order doubleword of memory; SDR stores the right portion of the register into the appropriate part of the low-order doubleword.

The SDL instruction adds its sign-extended 16-bit *offset* to the contents of general register *base* to form a virtual address which may specify an arbitrary byte. It alters only the word in memory which contains that byte. From one to four bytes will be stored, depending on the starting byte specified.

Conceptually, it starts at the most-significant byte of the register and copies it to the specified byte in memory; then it copies bytes from register to memory until it reaches the low-order byte of the word in memory.

No address exceptions due to alignment are possible.

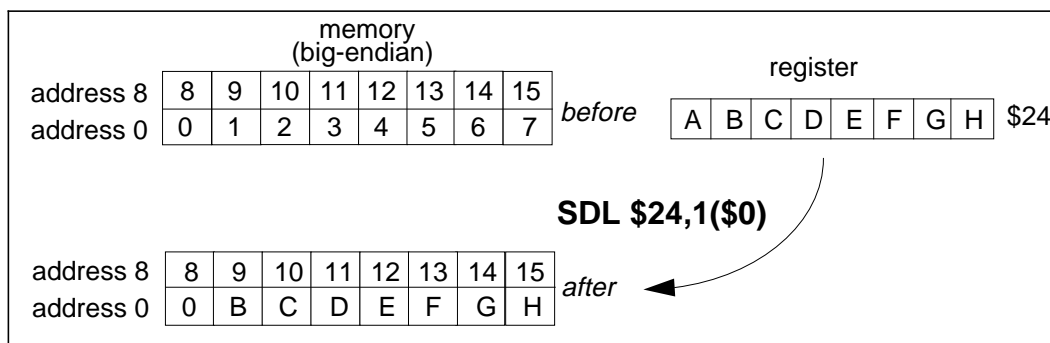

SDL**Store Doubleword Left
(continued)****SDL**

This operation is only defined for the R4000 operating in 64-bit mode. Execution of this instruction in 32-bit mode causes a reserved instruction exception.

Operation:

```

64   T:  vAddr ← ((offset15)48 || offset15...0) + GPR[base]
        (pAddr, uncached) ← AddressTranslation (vAddr, DATA)
        pAddr ← pAddrPSIZE-1...3 || (pAddr2...0 xor ReverseEndian3)
        If BigEndianMem = 0 then
            pAddr ← pAddr31...3 || 03
        endif
        byte ← vAddr2...0 xor BigEndianCPU3
        data ← 056-8*byte || GPR[rt]63...56-8*byte
        Storememory (uncached, byte, data, pAddr, vAddr, DATA)

```

SDL**Store Doubleword Left
(continued)****SDL**

Given a doubleword in a register and a doubleword in memory, the operation of SDL is as follows:

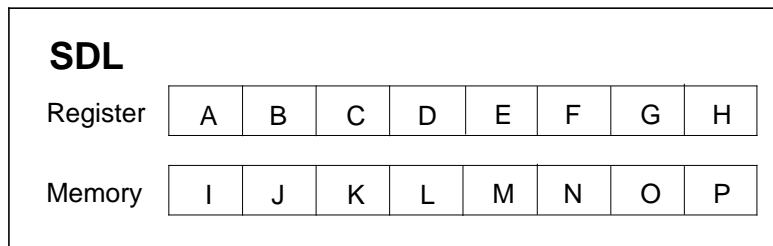

vAddr _{2..0}	BigEndianCPU = 0				BigEndianCPU = 1			
	destination	type	offset		destination	type	offset	
			LEM	BEM			LEM	BEM
0	I J K L M N O A	0	0	7	A B C D E F G H	7	0	0
1	I J K L M N A B	1	0	6	I A B C D E F G	6	0	1
2	I J K L M A B C	2	0	5	I J A B C D E F	5	0	2
3	I J K L A B C D	3	0	4	I J K A B C D E	4	0	3
4	I J K A B C D E	4	0	3	I J K L A B C D	3	0	4
5	I J A B C D E F	5	0	2	I J K L M A B C	2	0	5
6	I A B C D E F G	6	0	1	I J K L M N A B	1	0	6
7	A B C D E F G H	7	0	0	I J K L M N O A	0	0	7

LEM Little-endian memory (BigEndianMem = 0)

BEM BigEndianMem = 1

Type AccessType (see Table 2-1) sent to memory

Offset pAddr_{2..0} sent to memory

Exceptions:

TLB refill exception

TLB invalid exception

TLB modification exception

Bus error exception

Address error exception

Reserved instruction exception (R4000 in 32-bit mode)

SDR Store Doubleword Right SDR

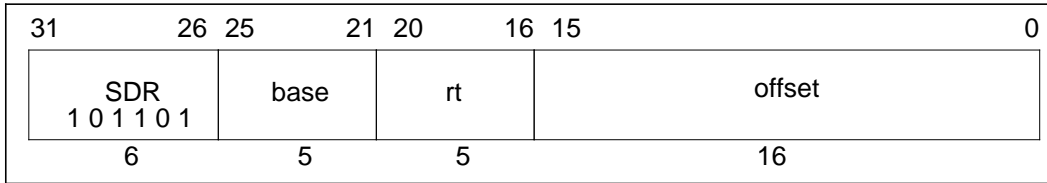

Format:

SDR rt, offset(base)

Description:

This instruction can be used with the SDL instruction to store the contents of a register into eight consecutive bytes of memory, when the bytes cross a boundary between two doublewords. SDR stores the right portion of the register into the appropriate part of the low-order doubleword; SDL stores the left portion of the register into the appropriate part of the low-order doubleword of memory.

The SDR instruction adds its sign-extended 16-bit *offset* to the contents of general register *base* to form a virtual address which may specify an arbitrary byte. It alters only the word in memory which contains that byte. From one to eight bytes will be stored, depending on the starting byte specified.

Conceptually, it starts at the least-significant (rightmost) byte of the register and copies it to the specified byte in memory; then it copies bytes from register to memory until it reaches the high-order byte of the word in memory. No address exceptions due to alignment are possible.

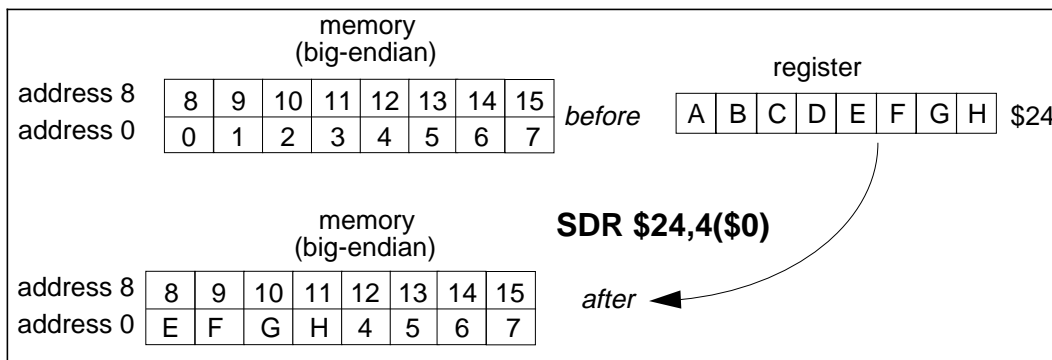

SDR**Store Doubleword Right
(continued)****SDR**

This operation is only defined for the R4000 operating in 64-bit mode.
Execution of this instruction in 32-bit mode causes a reserved instruction exception.

Operation:

```

64  T: vAddr ← ((offset15)48 || offset15..0) + GPR[base]
      (pAddr, uncached) ← AddressTranslation (vAddr, DATA)
      pAddr ← pAddrPSIZE-1..3 || (pAddr2..0 xor ReverseEndian3)
      If BigEndianMem = 0 then
        pAddr ← pAddrPSIZE-31..3 || 03
      endif
      byte ← vAddr1..0 xor BigEndianCPU3
      data ← GPR[rt]63-8*byte || 08*byte
      StoreMemory (uncached, DOUBLEWORD-byte, data, pAddr, vAddr, DATA)

```

SDR**Store Doubleword Right
(continued)****SDR**

Given a doubleword in a register and a doubleword in memory, the operation of SDR is as follows:

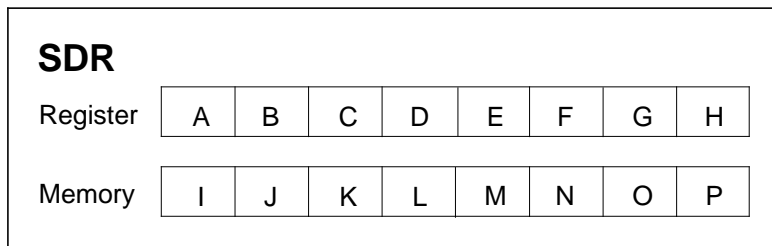

vAddr _{2..0}	BigEndianCPU = 0				BigEndianCPU = 1			
	destination	type	offset		destination	type	offset	
			LEM	BEM			LEM	BEM
0	A B C D E F G H	7	0	0	H J K L M N O P	0	7	0
1	B C D E F G H P	6	1	0	G H K L M N O P	1	6	0
2	C D E F G H O P	5	2	0	F G H L M N O P	2	5	0
3	D E F G H N O P	4	3	0	E F G H M N O P	3	4	0
4	E F G H M N O P	3	4	0	D E F G H N O P	4	3	0
5	F G H L M N O P	2	5	0	C D E F G H O P	5	2	0
6	G H K L M N O P	1	6	0	B C D E F G H P	6	1	0
7	H J K L M N O P	0	7	0	A B C D E F G H	7	0	0

LEM Little-endian memory (BigEndianMem = 0)
BEM BigEndianMem = 1
Type AccessType (see Table 2-1) sent to memory
Offset pAddr_{2..0} sent to memory

Exceptions:

TLB refill exception
 TLB invalid exception
 TLB modification exception
 Bus error exception
 Address error exception
 Reserved instruction exception (R4000 in 32-bit mode)

SH Store Halfword SH

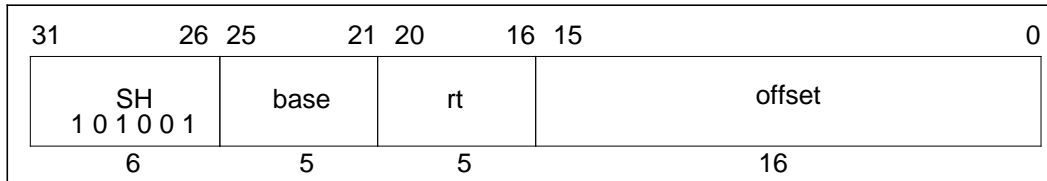
**Format:**SH *rt*, *offset*(*base*)**Description:**

The 16-bit *offset* is sign-extended and added to the contents of general register *base* to form an unsigned effective address. The least-significant halfword of register *rt* is stored at the effective address. If the least-significant bit of the effective address is non-zero, an address error exception occurs.

Operation:

32	T:	$vAddr \leftarrow ((offset_{15})^{16} \parallel offset_{15..0}) + GPR[base]$ $(pAddr, uncached) \leftarrow AddressTranslation(vAddr, DATA)$ $pAddr \leftarrow pAddr_{PSIZE-1..3} \parallel (pAddr_{2..0} \text{ xor } (ReverseEndian^2 \parallel 0))$ $byte \leftarrow vAddr_{2..0} \text{ xor } (BigEndianCPU^2 \parallel 0)$ $data \leftarrow GPR[rt]_{63-8*byte..0} \parallel 0^{8*byte}$ StoreMemory(uncached, HALFWORD, data, pAddr, vAddr, DATA)
64	T:	$vAddr \leftarrow ((offset_{15})^{48} \parallel offset_{15..0}) + GPR[base]$ $(pAddr, uncached) \leftarrow AddressTranslation(vAddr, DATA)$ $pAddr \leftarrow pAddr_{PSIZE-1..3} \parallel (pAddr_{2..0} \text{ xor } (ReverseEndian^2 \parallel 0))$ $byte \leftarrow vAddr_{2..0} \text{ xor } (BigEndianCPU^2 \parallel 0)$ $data \leftarrow GPR[rt]_{63-8*byte..0} \parallel 0^{8*byte}$ StoreMemory(uncached, HALFWORD, data, pAddr, vAddr, DATA)

Exceptions:

- TLB refill exception
- TLB invalid exception
- TLB modification exception
- Bus error exception
- Address error exception

SLL Shift Left Logical SLL

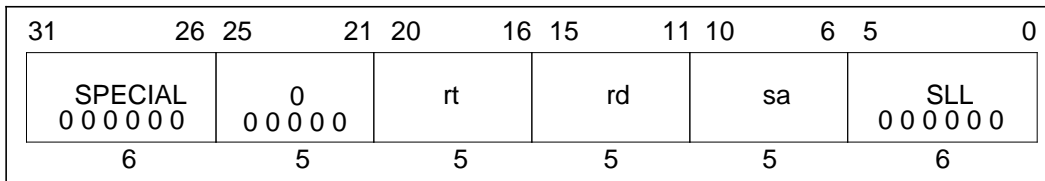
**Format:**

SLL rd, rt, sa

Description:

The contents of general register *rt* are shifted left by *sa* bits, inserting zeros into the low-order bits.

The result is placed in register *rd*.

In 64-bit mode, the 32-bit result is sign extended when placed in the destination register. It is sign extended for all shift amounts, including zero; SLL with a zero shift amount truncates a 64-bit value to 32 bits and then sign extends this 32-bit value. SLL, unlike nearly all other word operations, does not require an operand to be a properly sign-extended word value to produce a valid sign-extended word result.

NOTE: SLL with a shift amount of zero may be treated as a NOP by some assemblers, at some optimization levels. If using SLL with a zero shift to truncate 64-bit values, check the assembler you are using.

Operation:

32	T:	$GPR[rd] \leftarrow GPR[rt]_{31-sa..0} \parallel 0^{sa}$
64	T:	$s \leftarrow 0 \parallel sa$ $temp \leftarrow GPR[rt]_{31-s..0} \parallel 0^s$ $GPR[rd] \leftarrow (temp_{31})^{32} \parallel temp$

Exceptions:

None

SLLV Shift Left Logical Variable SLLV

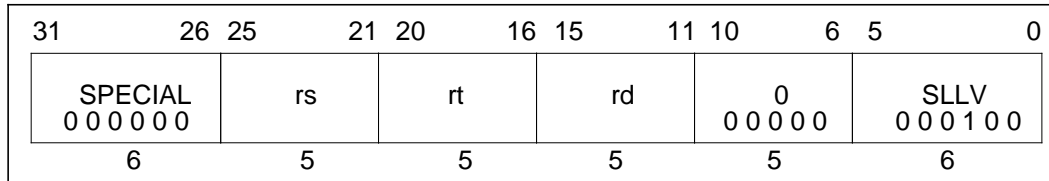
**Format:**

SLLV rd, rt, rs

Description:

The contents of general register *rt* are shifted left the number of bits specified by the low-order five bits contained in general register *rs*, inserting zeros into the low-order bits.

The result is placed in register *rd*.

In 64-bit mode, the 32-bit result is sign extended when placed in the destination register. It is sign extended for all shift amounts, including zero; SLLV with a zero shift amount truncates a 64-bit value to 32 bits and then sign extends this 32-bit value. SLLV, unlike nearly all other word operations, does not require an operand to be a properly sign-extended word value to produce a valid sign-extended word result.

NOTE: SLLV with a shift amount of zero may be treated as a NOP by some assemblers, at some optimization levels. If using SLLV with a zero shift to truncate 64-bit values, check the assembler you are using.

Operation:

32	T: $s \leftarrow \text{GP}[\text{rs}]_{4..0}$ $\text{GPR}[\text{rd}] \leftarrow \text{GPR}[\text{rt}]_{(31-s)..0} \parallel 0^s$
64	T: $s \leftarrow 0 \parallel \text{GP}[\text{rs}]_{4..0}$ $\text{temp} \leftarrow \text{GPR}[\text{rt}]_{(31-s)..0} \parallel 0^s$ $\text{GPR}[\text{rd}] \leftarrow (\text{temp}_{31})^{32} \parallel \text{temp}$

Exceptions:

None

SLT Set On Less Than SLT

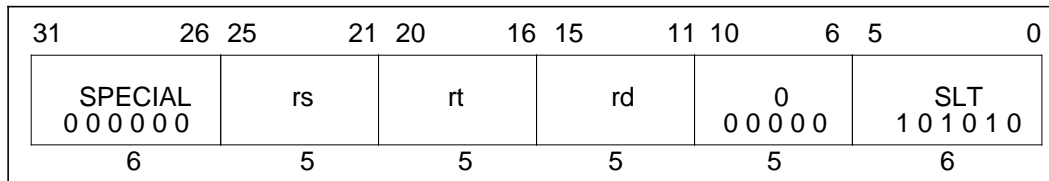
**Format:**

SLT rd, rs, rt

Description:

The contents of general register *rt* are subtracted from the contents of general register *rs*. Considering both quantities as signed integers, if the contents of general register *rs* are less than the contents of general register *rt*, the result is set to one; otherwise the result is set to zero.

The result is placed into general register *rd*.

No integer overflow exception occurs under any circumstances. The comparison is valid even if the subtraction used during the comparison overflows.

Operation:

32	T: if GPR[rs] < GPR[rt] then GPR[rd] ← 0 ³¹ 1 else GPR[rd] ← 0 ³² endif
64	T: if GPR[rs] < GPR[rt] then GPR[rd] ← 0 ⁶³ 1 else GPR[rd] ← 0 ⁶⁴ endif

Exceptions:

None

SLTI Set On Less Than Immediate SLTI

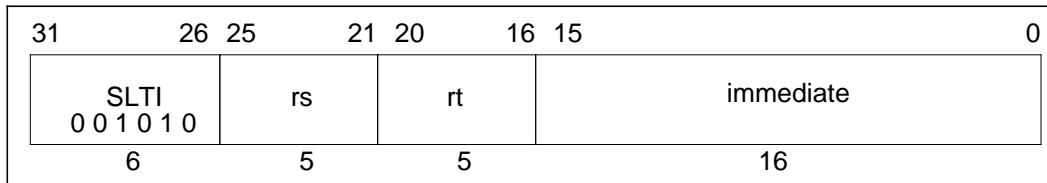
**Format:**

SLTI rt, rs, immediate

Description:

The 16-bit *immediate* is sign-extended and subtracted from the contents of general register *rs*. Considering both quantities as signed integers, if *rs* is less than the sign-extended immediate, the result is set to one; otherwise the result is set to zero.

The result is placed into general register *rt*.

No integer overflow exception occurs under any circumstances. The comparison is valid even if the subtraction used during the comparison overflows.

Operation:

32	T: if $GPR[rs] < (immediate_{15})^{16} immediate_{15...0}$ then <div style="padding-left: 20px;">$GPR[rd] \leftarrow 0^{31} 1$</div> <div style="padding-left: 20px;">else</div> <div style="padding-left: 20px;">$GPR[rd] \leftarrow 0^{32}$</div> <div style="padding-left: 20px;">endif</div>
64	T: if $GPR[rs] < (immediate_{15})^{48} immediate_{15...0}$ then <div style="padding-left: 20px;">$GPR[rd] \leftarrow 0^{63} 1$</div> <div style="padding-left: 20px;">else</div> <div style="padding-left: 20px;">$GPR[rd] \leftarrow 0^{64}$</div> <div style="padding-left: 20px;">endif</div>

Exceptions:

None

SLTIU Set On Less Than Immediate Unsigned SLTIU

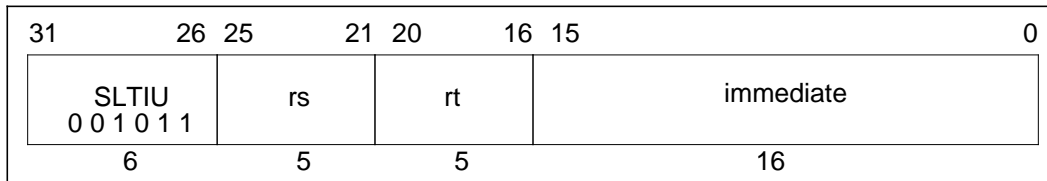
**Format:**

SLTIU rt, rs, immediate

Description:

The 16-bit *immediate* is sign-extended and subtracted from the contents of general register *rs*. Considering both quantities as unsigned integers, if *rs* is less than the sign-extended immediate, the result is set to one; otherwise the result is set to zero.

The result is placed into general register *rt*.

No integer overflow exception occurs under any circumstances. The comparison is valid even if the subtraction used during the comparison overflows.

Operation:

32	T: if $(0 \parallel \text{GPR}[\text{rs}]) < (\text{immediate}_{15})^{16} \parallel \text{immediate}_{15..0}$ then
	$\text{GPR}[\text{rd}] \leftarrow 0^{31} \parallel 1$
	else
	$\text{GPR}[\text{rd}] \leftarrow 0^{32}$
	endif
64	T: if $(0 \parallel \text{GPR}[\text{rs}]) < (\text{immediate}_{15})^{48} \parallel \text{immediate}_{15..0}$ then
	$\text{GPR}[\text{rd}] \leftarrow 0^{63} \parallel 1$
	else
	$\text{GPR}[\text{rd}] \leftarrow 0^{64}$
	endif

Exceptions:

None

SLTU Set On Less Than Unsigned SLTU

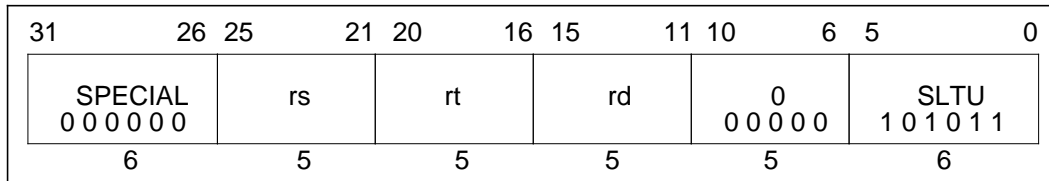
**Format:**

SLTU rd, rs, rt

Description:

The contents of general register *rt* are subtracted from the contents of general register *rs*. Considering both quantities as unsigned integers, if the contents of general register *rs* are less than the contents of general register *rt*, the result is set to one; otherwise the result is set to zero.

The result is placed into general register *rd*.

No integer overflow exception occurs under any circumstances. The comparison is valid even if the subtraction used during the comparison overflows.

Operation:

32	T: if (0 GPR[rs] < 0 GPR[rt] then GPR[rd] ← 0 ³¹ 1 else GPR[rd] ← 0 ³² endif
64	T: if (0 GPR[rs] < 0 GPR[rt] then GPR[rd] ← 0 ⁶³ 1 else GPR[rd] ← 0 ⁶⁴ endif

Exceptions:

None

SRA Shift Right Arithmetic SRA

31	26	25	21	20	16	15	11	10	6	5	0
SPECIAL 000000		0 00000		rt		rd		sa		SRA 000011	
6		5		5		5		5		6	

Format:

SRA rd, rt, sa

Description:

The contents of general register *rt* are shifted right by *sa* bits, sign-extending the high-order bits.

The result is placed in register *rd*.

In 64-bit mode, the operand must be a valid sign-extended, 32-bit value.

Operation:

32	T: $GPR[rd] \leftarrow (GPR[rt]_{31})^{sa} \parallel GPR[rt]_{31...sa}$
64	T: $s \leftarrow 0 \parallel sa$
	$temp \leftarrow (GPR[rt]_{31})^s \parallel GPR[rt]_{31...s}$
	$GPR[rd] \leftarrow (temp_{31})^{32} \parallel temp$

Exceptions:

None

SRAV Shift Right Arithmetic Variable SRAV

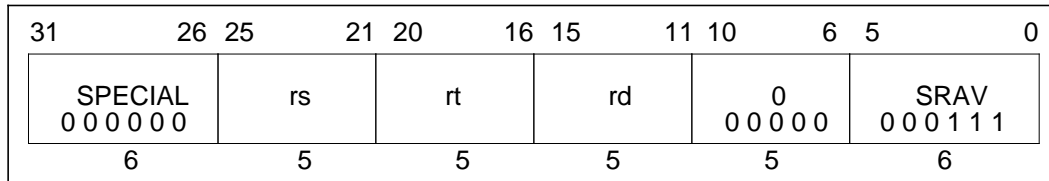
**Format:**

SRAV rd, rt, rs

Description:

The contents of general register *rt* are shifted right by the number of bits specified by the low-order five bits of general register *rs*, sign-extending the high-order bits.

The result is placed in register *rd*.

In 64-bit mode, the operand must be a valid sign-extended, 32-bit value.

Operation:

32	T: $s \leftarrow \text{GPR}[rs]_{4..0}$ $\text{GPR}[rd] \leftarrow (\text{GPR}[rt]_{31})^s \parallel \text{GPR}[rt]_{31..s}$
64	T: $s \leftarrow \text{GPR}[rs]_{4..0}$ $\text{temp} \leftarrow (\text{GPR}[rt]_{31})^s \parallel \text{GPR}[rt]_{31..s}$ $\text{GPR}[rd] \leftarrow (\text{temp}_{31})^{32} \parallel \text{temp}$

Exceptions:

None

SRL Shift Right Logical SRL

31	26	25	21	20	16	15	11	10	6	5	0
SPECIAL 000000		0 00000		rt		rd		sa		SRL 000010	
6		5		5		5		5		6	

Format:

SRL rd, rt, sa

Description:

The contents of general register *rt* are shifted right by *sa* bits, inserting zeros into the high-order bits.

The result is placed in register *rd*.

In 64-bit mode, the operand must be a valid sign-extended, 32-bit value.

Operation:

32	T: $GPR[rd] \leftarrow 0^{sa} \parallel GPR[rt]_{31...sa}$
64	T: $s \leftarrow 0 \parallel sa$ $temp \leftarrow 0^s \parallel GPR[rt]_{31...s}$ $GPR[rd] \leftarrow (temp_{31})^{32} \parallel temp$

Exceptions:

None

SRLV Shift Right Logical Variable SRLV

31	26 25	21 20	16 15	11 10	6 5	0
SPECIAL 0 0 0 0 0 0	rs	rt	rd	0 0 0 0 0 0	SRLV 0 0 0 1 1 0	
6	5	5	5	5	6	

Format:

SRLV rd, rt, rs

Description:

The contents of general register *rt* are shifted right by the number of bits specified by the low-order five bits of general register *rs*, inserting zeros into the high-order bits.

The result is placed in register *rd*.

In 64-bit mode, the operand must be a valid sign-extended, 32-bit value.

Operation:

32	T:	$s \leftarrow \text{GPR}[rs]_{4..0}$ $\text{GPR}[rd] \leftarrow 0^s \parallel \text{GPR}[rt]_{31..s}$
64	T:	$s \leftarrow \text{GPR}[rs]_{4..0}$ $\text{temp} \leftarrow 0^s \parallel \text{GPR}[rt]_{31..s}$ $\text{GPR}[rd] \leftarrow (\text{temp}_{31})^{32} \parallel \text{temp}$

Exceptions:

None

SUB Subtract SUB

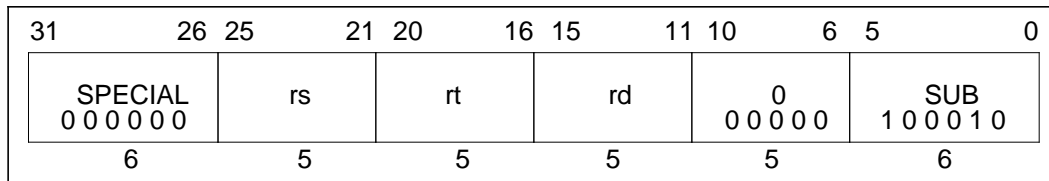
**Format:**

SUB rd, rs, rt

Description:

The contents of general register *rt* are subtracted from the contents of general register *rs* to form a result. The result is placed into general register *rd*. In 64-bit mode, the operands must be valid sign-extended, 32-bit values.

The only difference between this instruction and the SUBU instruction is that SUBU never traps on overflow.

An integer overflow exception takes place if the carries out of bits 30 and 31 differ (2's complement overflow). The destination register *rd* is not modified when an integer overflow exception occurs.

Operation:

32	T:	$GPR[rd] \leftarrow GPR[rs] - GPR[rt]$
64	T:	$temp \leftarrow GPR[rs] - GPR[rt]$ $GPR[rd] \leftarrow (temp_{31})^{32} temp_{31...0}$

Exceptions:

Integer overflow exception

SUBU Subtract Unsigned SUBU

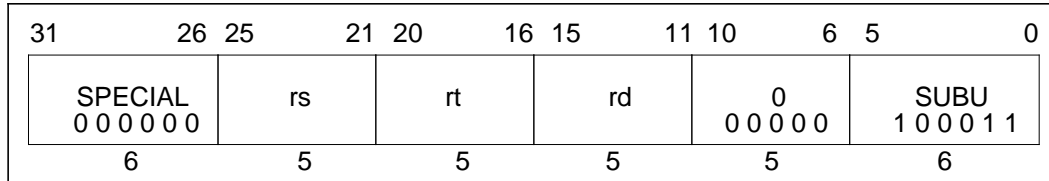
**Format:**

SUBU rd, rs, rt

Description:

The contents of general register *rt* are subtracted from the contents of general register *rs* to form a result.

The result is placed into general register *rd*.

In 64-bit mode, the operands must be valid sign-extended, 32-bit values.

The only difference between this instruction and the SUB instruction is that SUBU never traps on overflow. No integer overflow exception occurs under any circumstances.

Operation:

32	T: $GPR[rd] \leftarrow GPR[rs] - GPR[rt]$
64	T: $temp \leftarrow GPR[rs] - GPR[rt]$ $GPR[rd] \leftarrow (temp_{31})^{32} \parallel temp_{31...0}$

Exceptions:

None

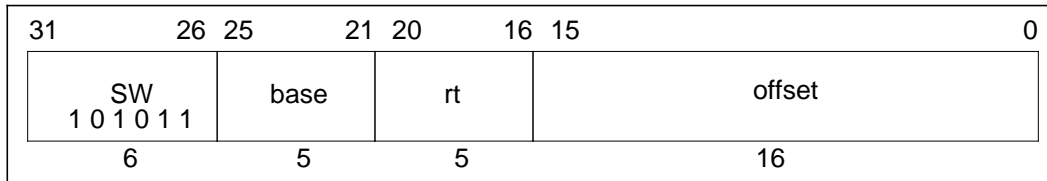
SW**Store Word****SW****Format:**

SW rt, offset(base)

Description:

The 16-bit *offset* is sign-extended and added to the contents of general register *base* to form a virtual address. The contents of general register *rt* are stored at the memory location specified by the effective address.

If either of the two least-significant bits of the effective address are non-zero, an address error exception occurs.

Operation:

32	<p>T: $vAddr \leftarrow ((offset_{15})^{16} \parallel offset_{15...0}) + GPR[base]$ $(pAddr, uncached) \leftarrow AddressTranslation(vAddr, DATA)$ $pAddr \leftarrow pAddr_{PSIZE-1...3} \parallel (pAddr_{2...0} \text{ xor } (ReverseEndian \parallel 0^2))$ $byte \leftarrow vAddr_{2...0} \text{ xor } (BigEndianCPU \parallel 0^2)$ $data \leftarrow GPR[rt]_{63-8+byte} \parallel 0^{8+byte}$ StoreMemory (uncached, WORD, data, pAddr, vAddr, DATA)</p>
64	<p>T: $vAddr \leftarrow ((offset_{15})^{48} \parallel offset_{15...0}) + GPR[base]$ $(pAddr, uncached) \leftarrow AddressTranslation(vAddr, DATA)$ $pAddr \leftarrow pAddr_{PSIZE-1...3} \parallel (pAddr_{2...0} \text{ xor } (ReverseEndian \parallel 0^2))$ $byte \leftarrow vAddr_{2...0} \text{ xor } (BigEndianCPU \parallel 0^2)$ $data \leftarrow GPR[rt]_{63-8+byte} \parallel 0^{8+byte}$ StoreMemory (uncached, WORD, data, pAddr, vAddr, DATA)</p>

Exceptions:

TLB refill exception	TLB invalid exception
TLB modification exception	Bus error exception
Address error exception	

SWCz Store Word From Coprocessor SWCz

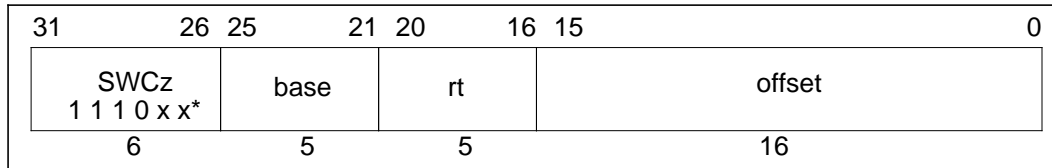
**Format:**

SWCz rt, offset(base)

Description:

The 16-bit *offset* is sign-extended and added to the contents of general register *base* to form a virtual address. Coprocessor unit *z* sources a word, which the processor writes to the addressed memory location.

The data to be stored is defined by individual coprocessor specifications.

This instruction is not valid for use with CP0.

If either of the two least-significant bits of the effective address is non-zero, an address error exception occurs.

Operation:

32	<p>T: $vAddr \leftarrow ((offset_{15})^{16} \parallel offset_{15..0}) + GPR[base]$ $(pAddr, uncached) \leftarrow AddressTranslation(vAddr, DATA)$ $pAddr \leftarrow pAddr_{P_{SIZE}-1..3} \parallel (pAddr_{2..0} \text{ xor } (ReverseEndian \parallel 0^2))$ $byte \leftarrow vAddr_{2..0} \text{ xor } (BigEndianCPU \parallel 0^2)$ $data \leftarrow COPzSW(byte, rt)$ StoreMemory(uncached, WORD, data, pAddr, vAddr, DATA)</p>
64	<p>T: $vAddr \leftarrow ((offset_{15})^{48} \parallel offset_{15..0}) + GPR[base]$ $(pAddr, uncached) \leftarrow AddressTranslation(vAddr, DATA)$ $pAddr \leftarrow pAddr_{P_{SIZE}-1..3} \parallel (pAddr_{2..0} \text{ xor } (ReverseEndian \parallel 0^2))$ $byte \leftarrow vAddr_{2..0} \text{ xor } (BigEndianCPU \parallel 0^2)$ $data \leftarrow COPzSW(byte, rt)$ StoreMemory(uncached, WORD, data, pAddr, vAddr, DATA)</p>

*See the table “Opcode Bit Encoding” on next page, or “CPU Instruction Opcode Bit Encoding” at the end of Appendix A.

SWCz Store Word From Coprocessor SWCz

(Continued)

Exceptions:

- TLB refill exception
- TLB invalid exception
- TLB modification exception
- Bus error exception
- Address error exception
- Coprocessor unusable exception

Opcode Bit Encoding:

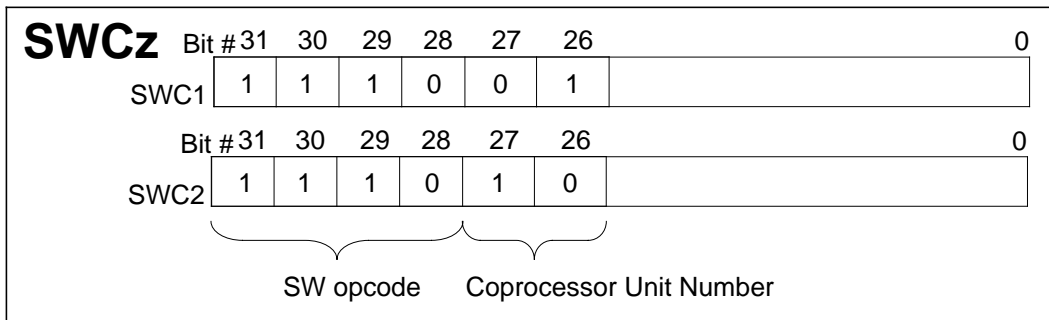

SWL Store Word Left SWL

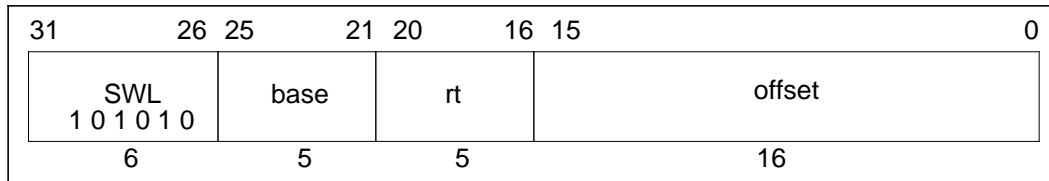
**Format:**

SWL rt, offset(base)

Description:

This instruction can be used with the SWR instruction to store the contents of a register into four consecutive bytes of memory, when the bytes cross a word boundary. SWL stores the left portion of the register into the appropriate part of the high-order word of memory; SWR stores the right portion of the register into the appropriate part of the low-order word.

The SWL instruction adds its sign-extended 16-bit *offset* to the contents of general register *base* to form a virtual address which may specify an arbitrary byte. It alters only the word in memory which contains that byte. From one to four bytes will be stored, depending on the starting byte specified.

Conceptually, it starts at the most-significant byte of the register and copies it to the specified byte in memory; then it copies bytes from register to memory until it reaches the low-order byte of the word in memory.

No address exceptions due to alignment are possible.

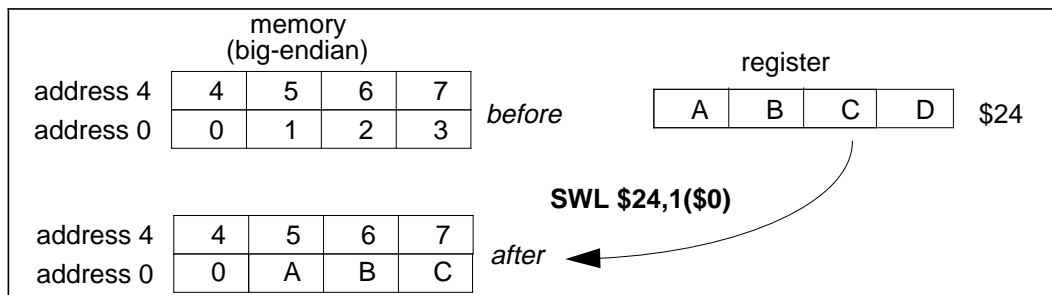

SWL**Store Word Left
(Continued)****SWL****Operation:**

```

32   T: vAddr ← ((offset15)16 || offset15...0) + GPR[base]
      (pAddr, uncached) ← AddressTranslation (vAddr, DATA)
      pAddr ← pAddrPSIZE-1...3 || (pAddr2...0 xor ReverseEndian3)
      If BigEndianMem = 0 then
        pAddr ← pAddr31...2 || 02
      endif
      byte ← vAddr1...0 xor BigEndianCPU2
      if (vAddr2 xor BigEndianCPU) = 0 then
        data ← 032 || 024-8*byte || GPR[rt]31...24-8*byte
      else
        data ← 024-8*byte || GPR[rt]31...24-8*byte || 032
      endif
      Storememory (uncached, byte, data, pAddr, vAddr, DATA)

64   T: vAddr ← ((offset15)48 || offset15...0) + GPR[base]
      (pAddr, uncached) ← AddressTranslation (vAddr, DATA)
      pAddr ← pAddrPSIZE-1...3 || (pAddr2...0 xor ReverseEndian3)
      If BigEndianMem = 0 then
        pAddr ← pAddr31...2 || 02
      endif
      byte ← vAddr1...0 xor BigEndianCPU2
      if (vAddr2 xor BigEndianCPU) = 0 then
        data ← 032 || 024-8*byte || GPR[rt]31...24-8*byte
      else
        data ← 024-8*byte || GPR[rt]31...24-8*byte || 032
      endif
      StoreMemory(uncached, byte, data, pAddr, vAddr, DATA)

```

SWL

Store Word Left (Continued)

SWL

Given a doubleword in a register and a doubleword in memory, the operation of SWL is as follows:

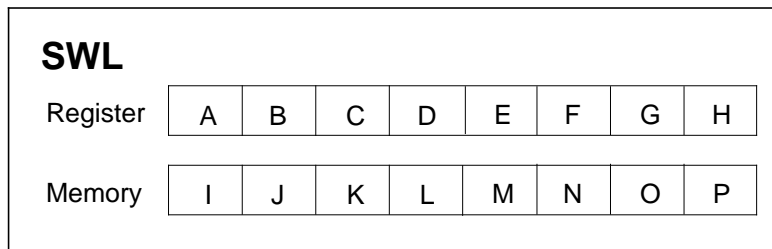

vAddr _{2..0}	BigEndianCPU = 0				BigEndianCPU = 1			
	destination	type	offset		destination	type	offset	
			LEM	BEM			LEM	BEM
0	I J K L M N O E	0	0	7	E F G H M N O P	3	4	0
1	I J K L M N E F	1	0	6	I E F G M N O P	2	4	1
2	I J K L M E F G	2	0	5	I J E F M N O P	1	4	2
3	I J K L E F G H	3	0	4	I J K E M N O P	0	4	3
4	I J K E M N O P	0	4	3	I J K L E F G H	3	0	4
5	I J E F M N O P	1	4	2	I J K L M E F G	2	0	5
6	I E F G M N O P	2	4	1	I J K L M N E F	1	0	6
7	E F G H M N O P	3	4	0	I J K L M N O E	0	0	7

LEM Little-endian memory (BigEndianMem = 0)
BEM BigEndianMem = 1
Type AccessType (see Table 2-1) sent to memory
Offset pAddr_{2...0} sent to memory

Exceptions:

- TLB refill exception
- TLB invalid exception
- TLB modification exception
- Bus error exception
- Address error exception

SWR Store Word Right SWR

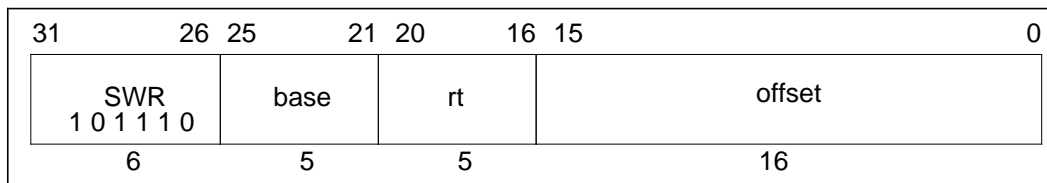
**Format:**

SWR rt, offset(base)

Description:

This instruction can be used with the SWL instruction to store the contents of a register into four consecutive bytes of memory, when the bytes cross a boundary between two words. SWR stores the right portion of the register into the appropriate part of the low-order word; SWL stores the left portion of the register into the appropriate part of the low-order word of memory.

The SWR instruction adds its sign-extended 16-bit *offset* to the contents of general register *base* to form a virtual address which may specify an arbitrary byte. It alters only the word in memory which contains that byte. From one to four bytes will be stored, depending on the starting byte specified.

Conceptually, it starts at the least-significant (rightmost) byte of the register and copies it to the specified byte in memory; then copies bytes from register to memory until it reaches the high-order byte of the word in memory.

No address exceptions due to alignment are possible.

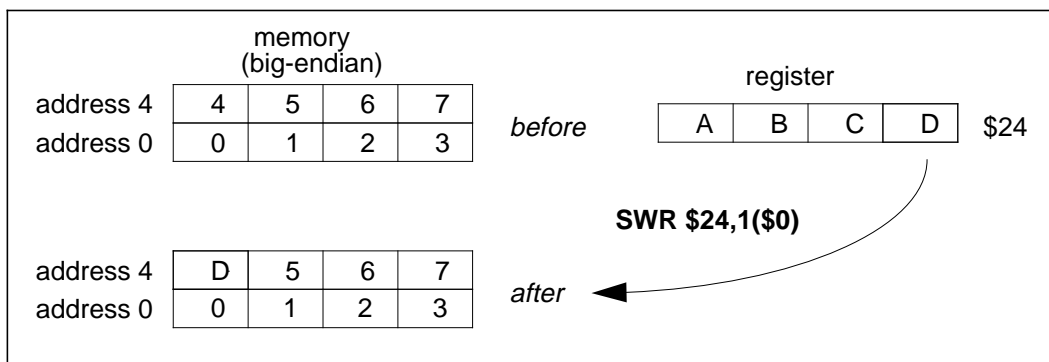

SWR**Store Word Right
(Continued)****SWR****Operation:**

```

32   T: vAddr ← ((offset15)16 || offset15...0) + GPR[base]
      (pAddr, uncached) ← AddressTranslation(vAddr, DATA)
      pAddr ← pAddrPSIZE-1...3 || (pAddr2...0 xor ReverseEndian3)
      If BigEndianMem = 0 then
        pAddr ← pAddr31...2 || 02
      endif
      byte ← vAddr1...0 xor BigEndianCPU2
      if (vAddr2 xor BigEndianCPU) = 0 then
        data ← 032 || GPR[rt]31-8*byte...0 || 08*byte
      else
        data ← GPR[rt]31-8*byte...0 || 08*byte || 032
      endif
      Storememory(uncached, WORD-byte, data, pAddr, vAddr, DATA)

64   T: vAddr ← ((offset15)48 || offset15...0) + GPR[base]
      (pAddr, uncached) ← AddressTranslation(vAddr, DATA)
      pAddr ← pAddrPSIZE-1...3 || (pAddr2...0 xor ReverseEndian3)
      If BigEndianMem = 0 then
        pAddr ← pAddr31...2 || 02
      endif
      byte ← vAddr1...0 xor BigEndianCPU2
      if (vAddr2 xor BigEndianCPU) = 0 then
        data ← 032 || GPR[rt]31-8*byte...0 || 08*byte
      else
        data ← GPR[rt]31-8*byte...0 || 08*byte || 032
      endif
      StoreMemory(uncached, WORD-byte, data, pAddr, vAddr, DATA)

```

SWR**Store Word Right
(Continued)****SWR**

Given a doubleword in a register and a doubleword in memory, the operation of SWR is as follows:

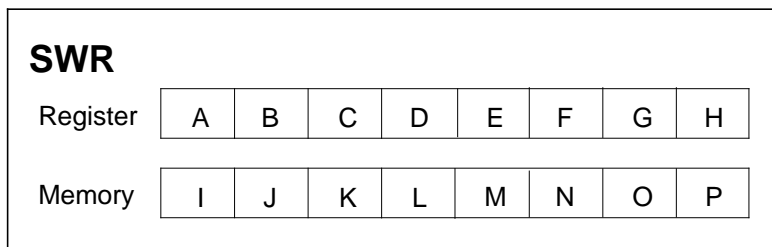

vAddr _{2..0}	BigEndianCPU = 0				BigEndianCPU = 1			
	destination	type	offset		destination	type	offset	
			LEM	BEM			LEM	BEM
0	I J K L E F G H	3	0	4	H J K L M N O P	0	7	0
1	I J K L F G H P	2	1	4	G H K L M N O P	1	6	0
2	I J K L G H O P	1	2	4	F G H L M N O P	2	5	0
3	I J K L H N O P	0	3	4	E F G H M N O P	3	4	0
4	E F G H M N O P	3	4	0	I J K L H N O P	0	3	4
5	F G H L M N O P	2	5	0	I J K L G H O P	1	2	4
6	G H K L M N O P	1	6	0	I J K L F G H P	2	1	4
7	H J K L M N O P	0	7	0	I J K L E F G H	3	0	4

LEM Little-endian memory (BigEndianMem = 0)
BEM BigEndianMem = 1
Type AccessType (see Table 2-1) sent to memory
Offset pAddr_{2...0} sent to memory

Exceptions:

TLB refill exception
 TLB invalid exception
 TLB modification exception
 Bus error exception
 Address error exception

SYNC Synchronize SYNC

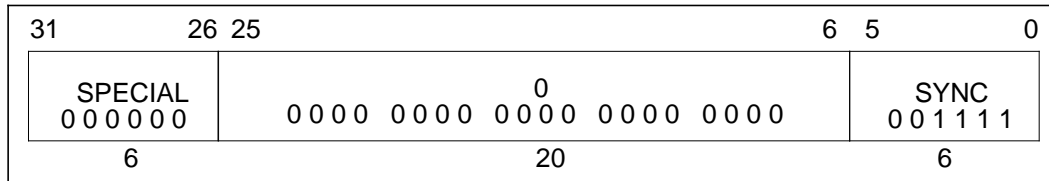
**Format:**

SYNC

Description:

The SYNC instruction ensures that any loads and stores fetched *prior to* the present instruction are completed before any loads or stores *after* this instruction are allowed to start. Use of the SYNC instruction to serialize certain memory references may be required in a multiprocessor environment for proper synchronization. For example:

Processor A		Processor B	
SW	R1, DATA	1:	LW R2, FLAG
LI	R2, 1		BEQ R2, R0, 1B
SYNC			NOP
SW	R2, FLAG		SYNC
			LW R1, DATA

The SYNC in processor A prevents DATA being written after FLAG, which could cause processor B to read stale data. The SYNC in processor B prevents DATA from being read before FLAG, which could likewise result in reading stale data. For processors which only execute loads and stores in order, with respect to shared memory, this instruction is a NOP.

LL and SC instructions implicitly perform a SYNC.

This instruction is allowed in User mode.

Operation:

32, 64	T: SyncOperation()
--------	--------------------

Exceptions:

None

TEQ Trap If Equal TEQ

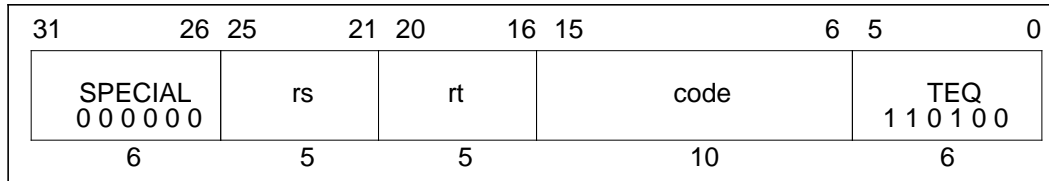
**Format:**

TEQ rs, rt

Description:

The contents of general register *rt* are compared to general register *rs*. If the contents of general register *rs* are equal to the contents of general register *rt*, a trap exception occurs.

The code field is available for use as software parameters, but is retrieved by the exception handler only by loading the contents of the memory word containing the instruction.

Operation:

```

32, 64    T:  if GPR[rs] = GPR[rt] then
              TrapException
            endif

```

Exceptions:

Trap exception

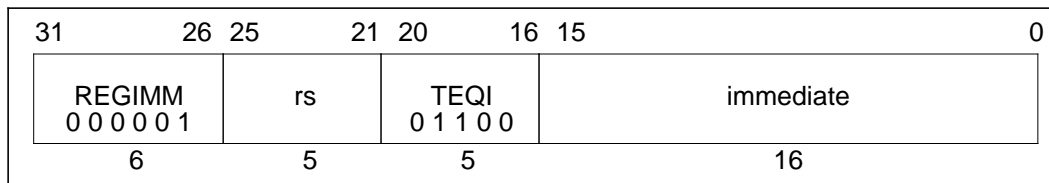
TEQI**Trap If Equal Immediate****TEQI****Format:**

TEQI rs, immediate

Description:

The 16-bit *immediate* is sign-extended and compared to the contents of general register *rs*. If the contents of general register *rs* are equal to the sign-extended *immediate*, a trap exception occurs.

Operation:

```

32  T:  if GPR[rs] = (immediate15)16 || immediate15...0 then
        TrapException
        endif

64  T:  if GPR[rs] = (immediate15)48 || immediate15...0 then
        TrapException
        endif

```

Exceptions:

Trap exception

TGE Trap If Greater Than Or Equal TGE

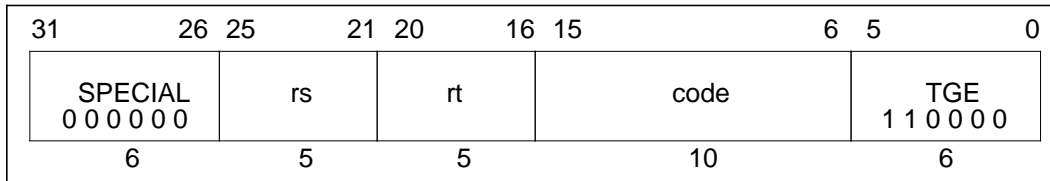
**Format:**

TGE rs, rt

Description:

The contents of general register *rt* are compared to the contents of general register *rs*. Considering both quantities as signed integers, if the contents of general register *rs* are greater than or equal to the contents of general register *rt*, a trap exception occurs.

The code field is available for use as software parameters, but is retrieved by the exception handler only by loading the contents of the memory word containing the instruction.

Operation:

```
32, 64 T: if GPR[rs] ≥ GPR[rt] then
          TrapException
        endif
```

Exceptions:

Trap exception

TGEI Trap If Greater Than Or Equal Immediate TGEI

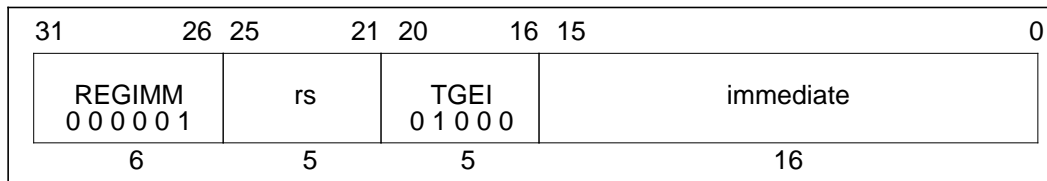
**Format:**

TGEI rs, immediate

Description:

The 16-bit *immediate* is sign-extended and compared to the contents of general register *rs*. Considering both quantities as signed integers, if the contents of general register *rs* are greater than or equal to the sign-extended *immediate*, a trap exception occurs.

Operation:

32	T: if $GPR[rs] \geq (immediate_{15})^{16} immediate_{15..0}$ then TrapException endif
64	T: if $GPR[rs] \geq (immediate_{15})^{48} immediate_{15..0}$ then TrapException endif

Exceptions:

Trap exception

TGEIU Trap If Greater Than Or Equal Immediate Unsigned TGEIU

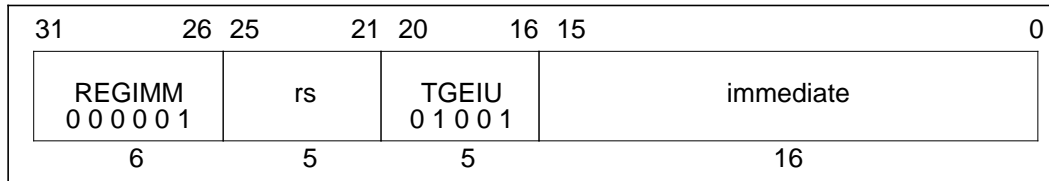
**Format:**

TGEIU rs, immediate

Description:

The 16-bit *immediate* is sign-extended and compared to the contents of general register *rs*. Considering both quantities as unsigned integers, if the contents of general register *rs* are greater than or equal to the sign-extended *immediate*, a trap exception occurs.

Operation:

32	T: if $(0 \parallel \text{GPR}[\text{rs}]) \geq (0 \parallel (\text{immediate}_{15})^{16} \parallel \text{immediate}_{15\dots 0})$ then TrapException endif
64	T: if $(0 \parallel \text{GPR}[\text{rs}]) \geq (0 \parallel (\text{immediate}_{15})^{48} \parallel \text{immediate}_{15\dots 0})$ then TrapException endif

Exceptions:

Trap exception

TGEU Trap If Greater Than Or Equal Unsigned TGEU

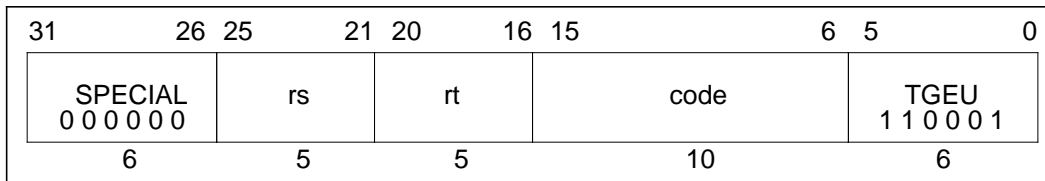
**Format:**

TGEU rs, rt

Description:

The contents of general register *rt* are compared to the contents of general register *rs*. Considering both quantities as unsigned integers, if the contents of general register *rs* are greater than or equal to the contents of general register *rt*, a trap exception occurs.

The code field is available for use as software parameters, but is retrieved by the exception handler only by loading the contents of the memory word containing the instruction.

Operation:

```
T:   if (0 || GPR[rs]) ≥ (0 || GPR[rt]) then
      TrapException
    endif
```

Exceptions:

Trap exception

TLBR Read Indexed TLB Entry TLBR

31	26	25	24	6	5	0	
COP0 010000		CO 1	0 000 0000 0000 0000 0000			TLBR 000001	
6		1	19			6	

Format:

TLBR

Description:

The *G* bit (which controls ASID matching) read from the TLB is written into both of the *EntryLo0* and *EntryLo1* registers.

The *EntryHi* and *EntryLo* registers are loaded with the contents of the TLB entry pointed at by the contents of the TLB *Index* register. The operation is invalid (and the results are unspecified) if the contents of the TLB *Index* register are greater than the number of TLB entries in the processor.

Operation:

32	T: PageMask \leftarrow TLB[Index _{5...0}] _{127...96} EntryHi \leftarrow TLB[Index _{5...0}] _{95...64} and not TLB[Index _{5...0}] _{127...96} EntryLo1 \leftarrow TLB[Index _{5...0}] _{63...32} EntryLo0 \leftarrow TLB[Index _{5...0}] _{31...0}
64	T: PageMask \leftarrow TLB[Index _{5...0}] _{255...192} EntryHi \leftarrow TLB[Index _{5...0}] _{191...128} and not TLB[Index _{5...0}] _{255...192} EntryLo1 \leftarrow TLB[Index _{5...0}] _{127...65} TLB[Index _{5...0}] ₁₄₀ EntryLo0 \leftarrow TLB[Index _{5...0}] _{63...1} TLB[Index _{5...0}] ₁₄₀

Exceptions:

Coprocessor unusable exception

TLBWR Write Random TLB Entry TLBWR

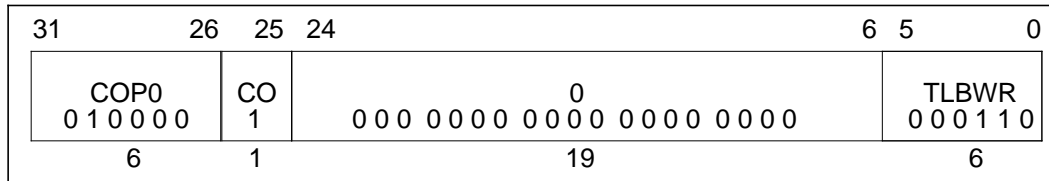
**Format:**

TLBWR

Description:

The *G* bit of the TLB is written with the logical AND of the *G* bits in the *EntryLo0* and *EntryLo1* registers.

The TLB entry pointed at by the contents of the TLB *Random* register is loaded with the contents of the *EntryHi* and *EntryLo* registers.

Operation:

32, 64T: TLB[Random_{5...0}] ←
PageMask || (EntryHi and not PageMask) || EntryLo1 || EntryLo0

Exceptions:

Coprocessor unusable exception

TLT Trap If Less Than TLT

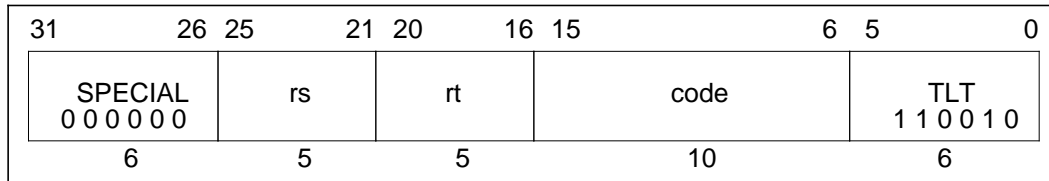
**Format:**

TLT rs, rt

Description:

The contents of general register *rt* are compared to general register *rs*. Considering both quantities as signed integers, if the contents of general register *rs* are less than the contents of general register *rt*, a trap exception occurs.

The code field is available for use as software parameters, but is retrieved by the exception handler only by loading the contents of the memory word containing the instruction.

Operation:

```

32, 64 T: if GPR[rs] < GPR[rt] then
           TrapException
        endif

```

Exceptions:

Trap exception

TLTI Trap If Less Than Immediate TLTI

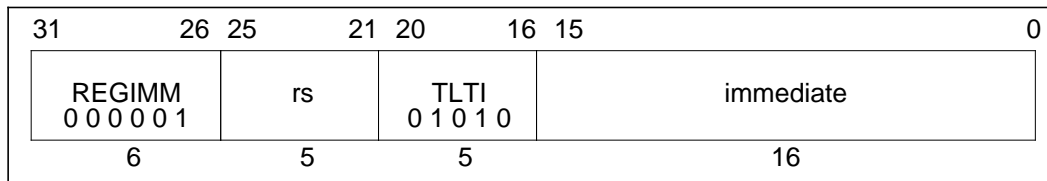
**Format:**

TLTI rs, immediate

Description:

The 16-bit *immediate* is sign-extended and compared to the contents of general register *rs*. Considering both quantities as signed integers, if the contents of general register *rs* are less than the sign-extended *immediate*, a trap exception occurs.

Operation:

32	T: if $GPR[rs] < (immediate_{15})^{16} immediate_{15..0}$ then TrapException endif
64	T: if $GPR[rs] < (immediate_{15})^{48} immediate_{15..0}$ then TrapException endif

Exceptions:

Trap exception

TLTIU Trap If Less Than Immediate Unsigned TLTIU

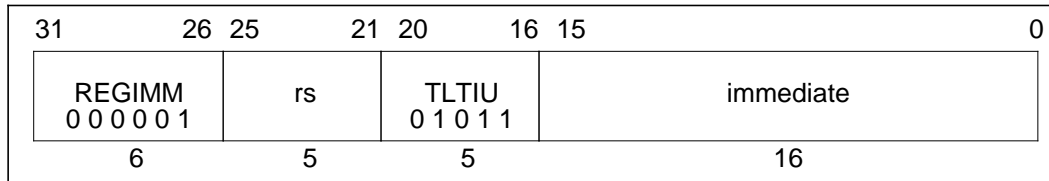
**Format:**

TLTIU rs, immediate

Description:

The 16-bit *immediate* is sign-extended and compared to the contents of general register *rs*. Considering both quantities as signed integers, if the contents of general register *rs* are less than the sign-extended *immediate*, a trap exception occurs.

Operation:

```

32   T:  if (0 || GPR[rs]) < (0 || (immediate15)16 || immediate15..0) then
        TrapException
        endif
64   T:  if (0 || GPR[rs]) < (0 || (immediate15)48 || immediate15..0) then
        TrapException
        endif

```

Exceptions:

Trap exception

TLTU Trap If Less Than Unsigned TLTU

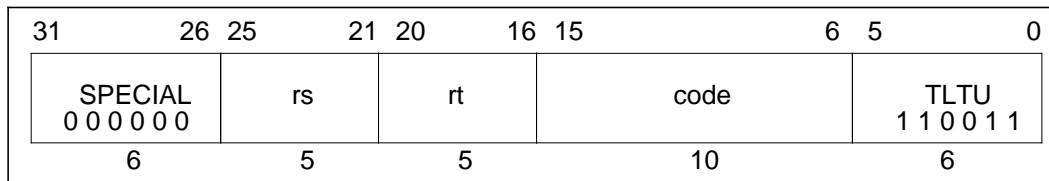
**Format:**

TLTU rs, rt

Description:

The contents of general register *rt* are compared to general register *rs*. Considering both quantities as unsigned integers, if the contents of general register *rs* are less than the contents of general register *rt*, a trap exception occurs.

The code field is available for use as software parameters, but is retrieved by the exception handler only by loading the contents of the memory word containing the instruction.

Operation:

```
32, 64T:   if (0 || GPR[rs]) < (0 || GPR[rt]) then
            TrapException
            endif
```

Exceptions:

Trap exception

TNE Trap If Not Equal TNE

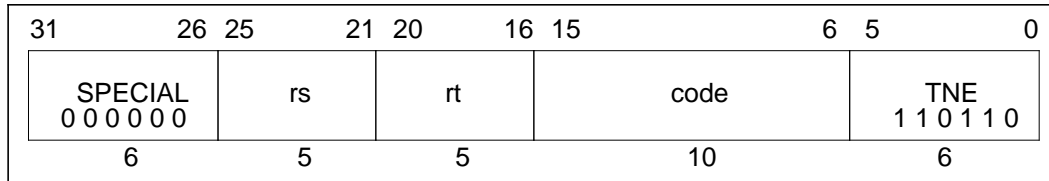
**Format:**

TNE rs, rt

Description:

The contents of general register *rt* are compared to general register *rs*. If the contents of general register *rs* are not equal to the contents of general register *rt*, a trap exception occurs.

The code field is available for use as software parameters, but is retrieved by the exception handler only by loading the contents of the memory word containing the instruction.

Operation:

```
32, 64T:  if GPR[rs] ≠ GPR[rt] then
           TrapException
           endif
```

Exceptions:

Trap exception

TNEI Trap If Not Equal Immediate TNEI

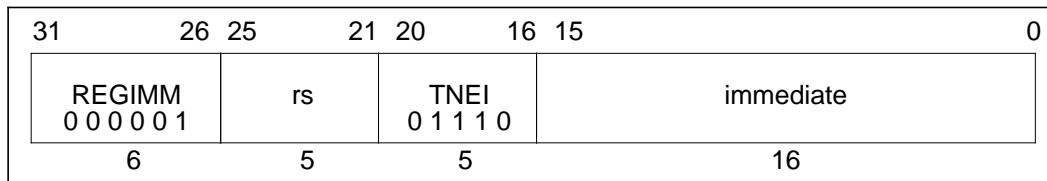
**Format:**

TNEI rs, immediate

Description:

The 16-bit *immediate* is sign-extended and compared to the contents of general register *rs*. If the contents of general register *rs* are not equal to the sign-extended *immediate*, a trap exception occurs.

Operation:

32	T: if $GPR[rs] \neq (immediate_{15})^{16} \parallel immediate_{15..0}$ then TrapException endif
64	T: if $GPR[rs] \neq (immediate_{15})^{48} \parallel immediate_{15..0}$ then TrapException endif

Exceptions:

Trap exception

XOR Exclusive Or XOR

31	26 25	21 20	16 15	11 10	6 5	0
SPECIAL 0 0 0 0 0 0	rs	rt	rd	0 0 0 0 0 0	XOR 1 0 0 1 1 0	
6	5	5	5	5	6	

Format:

XOR rd, rs, rt

Description:

The contents of general register *rs* are combined with the contents of general register *rt* in a bit-wise logical exclusive OR operation.

The result is placed into general register *rd*.

Operation:

32, 64	T: GPR[rd] ← GPR[rs] xor GPR[rt]
--------	----------------------------------

Exceptions:

None

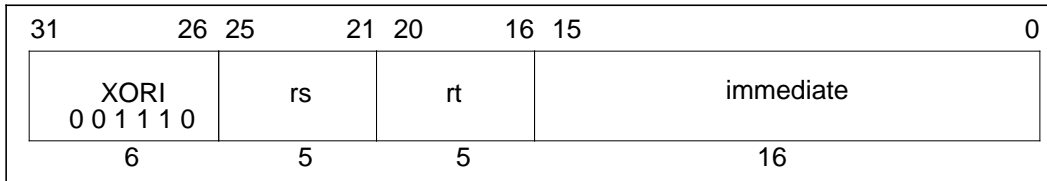
XORI**Exclusive OR Immediate****XORI****Format:**

XORI rt, rs, immediate

Description:

The 16-bit *immediate* is zero-extended and combined with the contents of general register *rs* in a bit-wise logical exclusive OR operation.

The result is placed into general register *rt*.

Operation:

32	T:	$GPR[rt] \leftarrow GPR[rs] \text{ xor } (0^{16} \parallel \text{immediate})$
64	T:	$GPR[rt] \leftarrow GPR[rs] \text{ xor } (0^{48} \parallel \text{immediate})$

Exceptions:

None

CPU Instruction Opcode Bit Encoding

The remainder of this Appendix presents the opcode bit encoding for the CPU instruction set (ISA and extensions), as implemented by the R4000. Figure A-2 lists the R4000 Opcode Bit Encoding.

		Opcode							
		28...26							7
31...29		0	1	2	3	4	5	6	7
0		SPECIAL	REGIMM	J	JAL	BEQ	BNE	BLEZ	BGTZ
1		ADDI	ADDIU	SLTI	SLTIU	ANDI	ORI	XORI	LUI
2		COP0	COP1	COP2	*	BEQL	BNEL	BLEZL	BGTZL
3		DADD _ε	DADDIU _ε	LDL _ε	LDR _ε	*	*	*	*
4		LB	LH	LWL	LW	LBU	LHU	LWR	LWU _ε
5		SB	SH	SWL	SW	SDL _ε	SDR _ε	SWR	CACHE δ
6		LL	LWC1	LWC2	*	LLD _ε	LDC1	LDC2	LD _ε
7		SC	SWC1	SWC2	*	SCD _ε	SDC1	SDC2	SD _ε
		SPECIAL function							
		2...0							7
5...3		0	1	2	3	4	5	6	7
0		SLL	*	SRL	SRA	SLLV	*	SRLV	SRAV
1		JR	JALR	*	*	SYSCALL	BREAK	*	SYNC
2		MFHI	MTHI	MFLO	MTLO	DSLLV _ε	*	DSRLV _ε	DSRAV _ε
3		MULT	MULTU	DIV	DIVU	DMULT _ε	DMULTU _ε	DDIV _ε	DDIVU _ε
4		ADD	ADDU	SUB	SUBU	AND	OR	XOR	NOR
5		*	*	SLT	SLTU	DADD _ε	DADDU _ε	DSUB _ε	DSUBU _ε
6		TGE	TGEU	TLT	TLTU	TEQ	*	TNE	*
7		DSLL _ε	*	DSRL _ε	DSRA _ε	DSLL32 _ε	*	DSRL32 _ε	DSRA32 _ε
		REGIMM rt							
		18...16							7
20...19		0	1	2	3	4	5	6	7
0		BLTZ	BGEZ	BLTZL	BGEZL	*	*	*	*
1		TGEI	TGEIU	TLTI	TLTIU	TEQI	*	TNEI	*
2		BLTZAL	BGEZAL	BLTZALL	BGEZALL	*	*	*	*
3		*	*	*	*	*	*	*	*
		COPz rs							
		23...21							7
25, 24		0	1	2	3	4	5	6	7
0		MF	DMF _ε	CF	γ	MT	DMT _ε	CT	γ
1		BC	γ	γ	γ	γ	γ	γ	γ
2		CO							
3									

Figure A-2 R4000 Opcode Bit Encoding

		COPz rt							
		18...16							
20...19		0	1	2	3	4	5	6	7
	0	BCF	BCT	BCFL	BCTL	γ	γ	γ	γ
	1	γ	γ	γ	γ	γ	γ	γ	γ
	2	γ	γ	γ	γ	γ	γ	γ	γ
	3	γ	γ	γ	γ	γ	γ	γ	γ

		CP0 Function							
		2...0							
5...3		0	1	2	3	4	5	6	7
	0	φ	TLBR	TLBWI	φ	φ	φ	TLBWR	φ
	1	TLBP	φ	φ	φ	φ	φ	φ	φ
	2	ξ	φ	φ	φ	φ	φ	φ	φ
	3	ERET χ	φ	φ	φ	φ	φ	φ	φ
	0	φ	φ	φ	φ	φ	φ	φ	φ
	1	φ	φ	φ	φ	φ	φ	φ	φ
	2	φ	φ	φ	φ	φ	φ	φ	φ
	3	φ	φ	φ	φ	φ	φ	φ	φ

Figure A-2 (cont.) R4000 Opcode Bit Encoding

Key:

- * Operation codes marked with an asterisk cause reserved instruction exceptions in all current implementations and are reserved for future versions of the architecture.
- γ Operation codes marked with a gamma cause a reserved instruction exception. They are reserved for future versions of the architecture.
- δ Operation codes marked with a delta are valid only for R4000 processors with CP0 enabled, and cause a reserved instruction exception on other processors.
- φ Operation codes marked with a phi are invalid but do not cause reserved instruction exceptions in R4000 implementations.
- ξ Operation codes marked with a xi cause a reserved instruction exception on R4000 processors.
- χ Operation codes marked with a chi are valid only on R4000.
- ε Operation codes marked with epsilon are valid when the processor is operating either in the Kernel mode or in the 64-bit non-Kernel (User or Supervisor) mode. These instructions cause a reserved instruction exception if 64-bit operation is not enabled in User or Supervisor mode.

FPU Instruction Set Details

B

This appendix provides a detailed description of each floating-point unit (FPU) instruction (refer to Appendix A for a detailed description of the CPU instructions). The instructions are listed alphabetically, and any exceptions that may occur due to the execution of each instruction are listed after the description of each instruction. Descriptions of the immediate causes and the manner of handling exceptions are omitted from the instruction descriptions in this appendix (refer to Chapter 7 for detailed descriptions of floating-point exceptions and handling).

Figure B-3 at the end of this appendix lists the entire bit encoding for the constant fields of the floating-point instruction set; the bit encoding for each instruction is included with that individual instruction.

B.1 Instruction Formats

There are three basic instruction format types:

- I-Type, or Immediate instructions, which include load and store operations
- M-Type, or Move instructions
- R-Type, or Register instructions, which include the two- and three-register floating-point operations.

The instruction description subsections that follow show how these three basic instruction formats are used by:

- Load and store instructions
- Move instructions
- Floating-Point computational instructions
- Floating-Point branch instructions

Floating-point instructions are mapped onto the MIPS coprocessor instructions, defining coprocessor unit number one (CP1) as the floating-point unit.

Each operation is valid only for certain formats. Implementations may support some of these formats and operations through emulation, but they only need to support combinations that are valid (marked *V* in Table B-1). Combinations marked *R* in Table B-1 are not currently specified by this architecture, and cause an unimplemented operation trap. They will be available for future extensions to the architecture.

Table B-1 Valid FPU Instruction Formats

Operation	Source Format			
	Single	Double	Word	Longword
ADD	V	V	R	R
SUB	V	V	R	R
MUL	V	V	R	R
DIV	V	V	R	R
SQRT	V	V	R	R
ABS	V	V	R	R
MOV	V	V		
NEG	V	V	R	R
TRUNC.L	V	V		
ROUND.L	V	V		
CEIL.L	V	V		
FLOOR.L	V	V		
TRUNC.W	V	V		
ROUND.W	V	V		
CEIL.W	V	V		
FLOOR.W	V	V		
CVT.S		V	V	V
CVT.D	V		V	V
CVT.W	V	V		
CVT.L	V	V		
C	V	V	R	R

The coprocessor branch on condition true/false instructions can be used to logically negate any predicate. Thus, the 32 possible conditions require only 16 distinct comparisons, as shown in Table B-2 below.

Table B-2 Logical Negation of Predicates by Condition True/False

Condition			Relations				Invalid Operation Exception If Unordered
Mnemonic		Code	Greater Than	Less Than	Equal	Unordered	
True	False						
F	T	0	F	F	F	F	No
UN	OR	1	F	F	F	T	No
EQ	NEQ	2	F	F	T	F	No
UEQ	OGL	3	F	F	T	T	No
OLT	UGE	4	F	T	F	F	No
ULT	OGE	5	F	T	F	T	No
OLE	UGT	6	F	T	T	F	No
ULE	OGT	7	F	T	T	T	No
SF	ST	8	F	F	F	F	Yes
NGLE	GLE	9	F	F	F	T	Yes
SEQ	SNE	10	F	F	T	F	Yes
NGL	GL	11	F	F	T	T	Yes
LT	NLT	12	F	T	F	F	Yes
NGE	GE	13	F	T	F	T	Yes
LE	NLE	14	F	T	T	F	Yes
NGT	GT	15	F	T	T	T	Yes

Floating-Point Loads, Stores, and Moves

All movement of data between the floating-point coprocessor and memory is accomplished by coprocessor load and store operations, which reference the floating-point coprocessor *General Purpose* registers. These operations are unformatted; no format conversions are performed and, therefore, no floating-point exceptions can occur due to these operations.

Data may also be directly moved between the floating-point coprocessor and the processor by *move to coprocessor* and *move from coprocessor* instructions. Like the floating-point load and store operations, move to/from operations perform no format conversions and never cause floating-point exceptions.

An additional pair of coprocessor registers are available, called *Floating-Point Control* registers for which the only data movement operations supported are moves to and from processor *General Purpose* registers.

Floating-Point Operations

The floating-point unit operation set includes:

- floating-point add
- floating-point subtract
- floating-point multiply
- floating-point divide
- floating-point square root
- convert between fixed-point and floating-point formats
- convert between floating-point formats
- floating-point compare

These operations satisfy the requirements of IEEE Standard 754 requirements for accuracy. Specifically, these operations obtain a result which is identical to an infinite-precision result rounded to the specified format, using the current rounding mode.

Instructions must specify the format of their operands. Except for conversion functions, mixed-format operations are not provided.

B.2 Instruction Notation Conventions

In this appendix, all variable subfields in an instruction format (such as *fs*, *ft*, *immediate*, and so on) are shown in lower-case. The instruction name (such as ADD, SUB, and so on) is shown in upper-case.

For the sake of clarity, we sometimes use an alias for a variable subfield in the formats of specific instructions. For example, we use *rs = base* in the format for load and store instructions. Such an alias is always lower case, since it refers to a variable subfield.

In some instructions, the instruction subfields *op* and *function* can have constant 6-bit values. When reference is made to these instructions, upper-case mnemonics are used. For instance, in the floating-point ADD instruction we use *op = COP1* and *function = ADD*. In other cases, a single field has both fixed and variable subfields, so the name contains both upper and lower case characters. Bit encodings for mnemonics are shown in Figure B-3 at the end of this appendix, and are also included with each individual instruction.

In the instruction description examples that follow, the *Operation* section describes the operation performed by each instruction using a high-level language notation.

Instruction Notation Examples

The following examples illustrate the application of some of the instruction notation conventions:

Example #1:

$$\text{GPR}[rt] \leftarrow \text{immediate} \parallel 0^{16}$$

Sixteen zero bits are concatenated with an immediate value (typically 16 bits), and the 32-bit string (with the lower 16 bits set to zero) is assigned to General Purpose Register *rt*.

Example #2:

$$(\text{immediate}_{15})^{16} \parallel \text{immediate}_{15..0}$$

Bit 15 (the sign bit) of an immediate value is extended for 16 bit positions, and the result is concatenated with bits 15 through 0 of the immediate value to form a 32-bit sign extended value.

B.3 Load and Store Instructions

In the R4000 implementation, the instruction immediately following a load may use the contents of the register being loaded. In such cases, the hardware *interlocks*, requiring additional real cycles, so scheduling load delay slots is still desirable, although not required for functional code.

The behavior of the load store instructions is dependent on the width of the *FGRs*.

- When the *FR* bit in the *Status* register equals zero, the *Floating-Point General* registers (*FGRs*) are 32-bits wide.
- When the *FR* bit in the *Status* register equals one, the *Floating-Point General* registers (*FGRs*) are 64-bits wide.

In the load and store operation descriptions, the functions listed in Table B-3 are used to summarize the handling of virtual addresses and physical memory.

Table B-3 Load and Store Common Functions

Function	Meaning
AddressTranslation	Uses the TLB to find the physical address given the virtual address. The function fails and an exception is taken if the required translation is not present in the TLB.
LoadMemory	Uses the cache and main memory to find the contents of the word containing the specified physical address. The low-order two bits of the address and the <i>Access Type</i> field indicates which of each of the four bytes within the data word need to be returned. If the cache is enabled for this access, the entire word is returned and loaded into the cache.
StoreMemory	Uses the cache, write buffer, and main memory to store the word or part of word specified as data in the word containing the specified physical address. The low-order two bits of the address and the <i>Access Type</i> field indicates which of each of the four bytes within the data word should be stored.

Figure B-1 shows the I-Type instruction format used by load and store operations.

I-Type (Immediate)

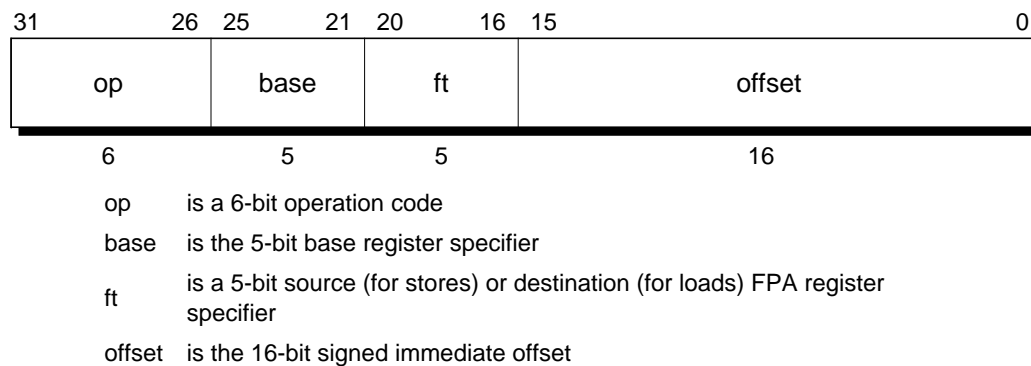

Figure B-1 Load and Store Instruction Format

All coprocessor loads and stores reference aligned data items. Thus, for word loads and stores, the access type field is always WORD, and the low-order two bits of the address must always be zero.

For doubleword loads and stores, the access type field is always DOUBLEWORD, and the low-order three bits of the address must always be zero.

Regardless of byte-numbering order (endianness), the address specifies that byte which has the smallest byte-address in the addressed field. For a big-endian machine, this is the leftmost byte; for a little-endian machine, this is the rightmost byte.

B.4 Computational Instructions

Computational instructions include all of the arithmetic floating-point operations performed by the FPU.

Figure B-2 shows the R-Type instruction format used for computational operations.

R-Type (Register)

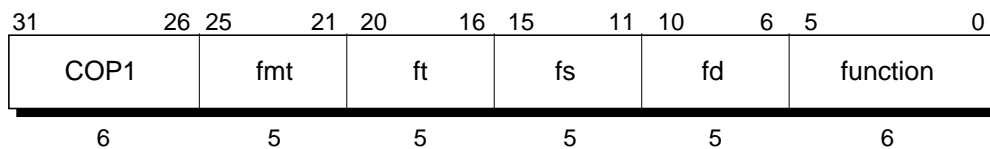

- COP1 is a 6-bit operation code
- fmt is a 5-bit format specifier
- fs is a 5-bit source1 register
- ft is a 5-bit source2 register
- fd is a 5-bit destination register
- function is a 6-bit function field

Figure B-2 Computational Instruction Format

The *function* field indicates the floating-point operation to be performed.

Each floating-point instruction can be applied to a number of operand *formats*. The operand format for an instruction is specified by the 5-bit *format* field; decoding for this field is shown in Table B-4.

Table B-4 Format Field Decoding

Code	Mnemonic	Size	Format
16	S	single	Binary floating-point
17	D	double	Binary floating-point
18	Reserved		
19	Reserved		
20	W	single	32-bit binary fixed-point
21	L	longword	64-bit binary fixed-point
22-31	Reserved		

Table B-5 lists all floating-point instructions.

Table B-5 Floating-Point Instructions and Operations

Code (5: 0)	Mnemonic	Operation
0	ADD	Add
1	SUB	Subtract
2	MUL	Multiply
3	DIV	Divide
4	SQRT	Square root
5	ABS	Absolute value
6	MOV	Move
7	NEG	Negate
8	ROUND.L	Convert to 64-bit (long) fixed-point, rounded to nearest/even
9	TRUNC.L	Convert to 64-bit (long) fixed-point, rounded toward zero
10	CEIL.L	Convert to 64-bit (long) fixed-point, rounded to $+\infty$
11	FLOOR.L	Convert to 64-bit (long) fixed-point, rounded to $-\infty$
12	ROUND.W	Convert to single fixed-point, rounded to nearest/even
13	TRUNC.W	Convert to single fixed-point, rounded toward zero
14	CEIL.W	Convert to single fixed-point, rounded to $+\infty$
15	FLOOR.W	Convert to single fixed-point, rounded to $-\infty$
16-31	-	Reserved
32	CVT.S	Convert to single floating-point
33	CVT.D	Convert to double floating-point
34	-	Reserved
35	-	Reserved
36	CVT.W	Convert to 32-bit binary fixed-point
37	CVT.L	Convert to 64-bit (long) binary fixed-point
38-47	-	Reserved
48-63	C	Floating-point compare

In the following pages, the notation *FGR* refers to the 32 *General Purpose* registers *FGR0* through *FGR31* of the FPU, and *FPR* refers to the floating-point registers of the FPU.

- When the *FR* bit in the *Status* register (SR(26)) equals zero, only the even floating-point registers are valid and the 32 *General Purpose* registers of the FPU are 32-bits wide.
- When the *FR* bit in the *Status* register (SR(26)) equals one, both odd and even floating-point registers may be used and the 32 *General Purpose* registers of the FPU are 64-bits wide.

The following routines are used in the description of the floating-point operations to retrieve the value of an FPR or to change the value of an FGR:

```

value ← ValueFPR(fpr,fmt)

if SR26 = 1 then /* 64-bit wide FGRs */
  case fmt of
    S, W:
      value ← FGR[fpr]31...0
      return
    D, L:
      value ← FGR[fpr]
      return
  endcase
elseif fpr0 = 0 then /* valid specifier, 32-bit wide FGRs */
  case fmt of
    S, W:
      value ← FGR[fpr]
      return
    D, L:
      value ← FGR[fpr+1] || FGR[fpr]
      return
  endcase
else /* undefined result for odd 32-bit reg #s */
  value ← undefined
endif

```

StoreFPR(fpr, fmt, value)

```
if SR26 = 1 then /* 64-bit wide FGRs */
  case fmt of
    S, W:
      FGR[fpr] ← undefined32 || value
      return
    D, L:
      FGR[fpr] ← value
      return
  endcase
elseif fpr0 = 0 then /* valid specifier, 32-bit wide FGRs */
  case fmt of
    S, W:
      FGR[fpr+1] ← undefined
      FGR[fpr] ← value
      return
    D, L:
      FGR[fpr+1] ← value63...32
      FGR[fpr] ← value31...0
      return
  endcase
else /* undefined result for odd 32-bit reg #s */
  undefined_result
endif
```

ABS.fmt Floating-Point Absolute Value ABS.fmt

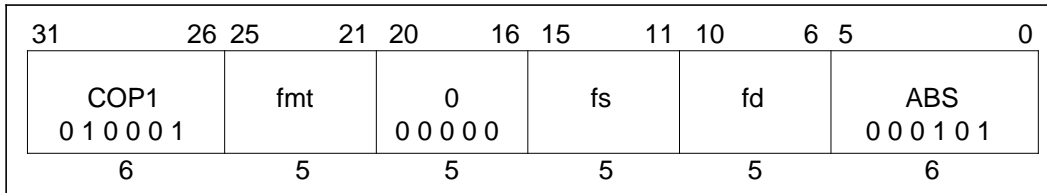
**Format:**

ABS.fmt fd, fs

Description:

The contents of the FPU register specified by *fs* are interpreted in the specified format and the arithmetic absolute value is taken. The result is placed in the floating-point register specified by *fd*.

The absolute value operation is arithmetic; a NaN operand signals invalid operation.

This instruction is valid only for single- and double-precision floating-point formats. The operation is not defined if bit 0 of any register specification is set and the *FR* bit in the *Status* register equals zero, since the register numbers specify an even-odd pair of adjacent coprocessor general registers. When the *FR* bit in the *Status* register equals one, both even and odd register numbers are valid.

Operation:

T: StoreFPR(fd, fmt, AbsoluteValue(ValueFPR(fs, fmt)))

Exceptions:

- Coprocessor unusable exception
- Coprocessor exception trap

Coprocessor Exceptions:

- Unimplemented operation exception
- Invalid operation exception

ADD.fmt Floating-Point Add ADD.fmt

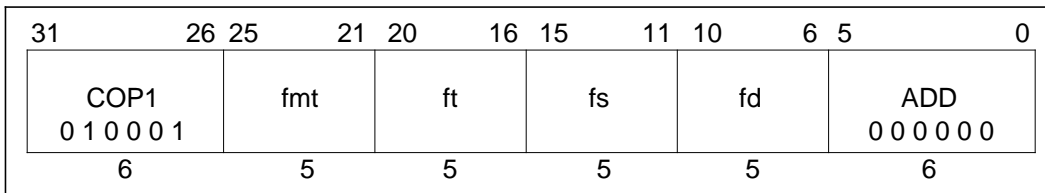
**Format:**ADD.fmt *fd*, *fs*, *ft***Description:**

The contents of the FPU registers specified by *fs* and *ft* are interpreted in the specified format and arithmetically added. The result is rounded as if calculated to infinite precision and then rounded to the specified format (*fmt*), according to the current rounding mode. The result is placed in the floating-point register (*FPR*) specified by *fd*.

This instruction is valid only for single- and double-precision floating-point formats. The operation is not defined if bit 0 of any register specification is set and the *FR* bit in the *Status* register equals zero, since the register numbers specify an even-odd pair of adjacent coprocessor general registers. When the *FR* bit in the *Status* register equals one, both even and odd register numbers are valid.

Operation:

T: StoreFPR (<i>fd</i> , <i>fmt</i> , ValueFPR(<i>fs</i> , <i>fmt</i>) + ValueFPR(<i>ft</i> , <i>fmt</i>))
--

Exceptions:

- Coprocessor unusable exception
- Floating-Point exception

Coprocessor Exceptions:

- Unimplemented operation exception
- Invalid operation exception
- Inexact exception
- Overflow exception
- Underflow exception

BC1F Branch On FPA False (Coprocessor 1) BC1F

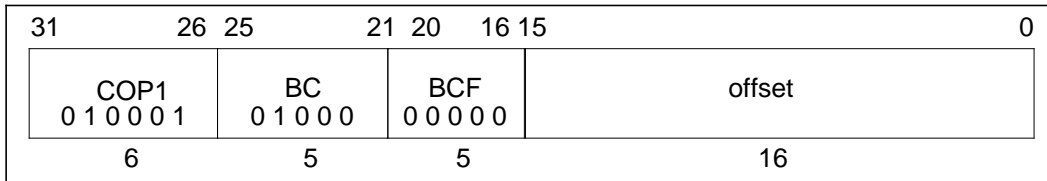
**Format:**

BC1F offset

Description:

A branch target address is computed from the sum of the address of the instruction in the delay slot and the 16-bit *offset*, shifted left two bits and sign-extended. If the result of the last floating-point compare is false (zero), the program branches to the target address, with a delay of one instruction.

There must be at least one instruction between C.cond.fmt and BC1F.

Operation:

32	T-1: condition \leftarrow not COC[1]
	T: target \leftarrow (offset ₁₅) ¹⁴ offset 0 ²
	T+1: if condition then
	PC \leftarrow PC + target
	endif
64	T-1: condition \leftarrow not COC[1]
	T: target \leftarrow (offset ₁₅) ⁴⁶ offset 0 ²
	T+1: if condition then
	PC \leftarrow PC + target
	endif

Exceptions:

Coprocessor unusable exception

BC1FL Branch On FPU False Likely (Coprocessor 1) BC1FL

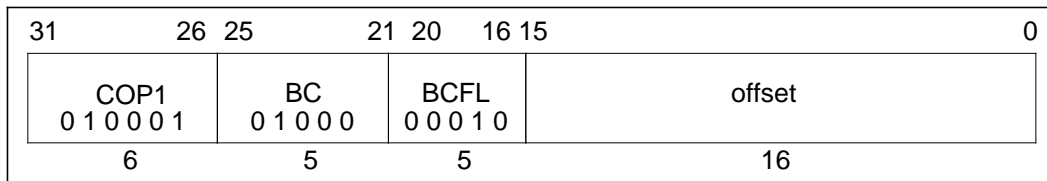
**Format:**

BC1FL offset

Description:

A branch target address is computed from the sum of the address of the instruction in the delay slot and the 16-bit *offset*, shifted left two bits and sign-extended. If the result of the last floating-point compare is false (zero), the program branches to the target address, with a delay of one instruction. If the conditional branch is not taken, the instruction in the branch delay slot is nullified.

There must be at least one instruction between C.cond.fmt and BC1FL.

Operation:

32	T-1: condition \leftarrow not COC[1]
	T: target \leftarrow (offset ₁₅) ¹⁴ offset 0 ²
	T+1: if condition then
	PC \leftarrow PC + target
	else
	NullifyCurrentInstruction
	endif
64	T-1: condition \leftarrow not COC[1]
	T: target \leftarrow (offset ₁₅) ⁴⁶ offset 0 ²
	T+1: if condition then
	PC \leftarrow PC + target
	else
	NullifyCurrentInstruction
	endif

Exceptions:

Coprocessor unusable exception

BC1T Branch On FPU True (Coprorocessor 1) BC1T

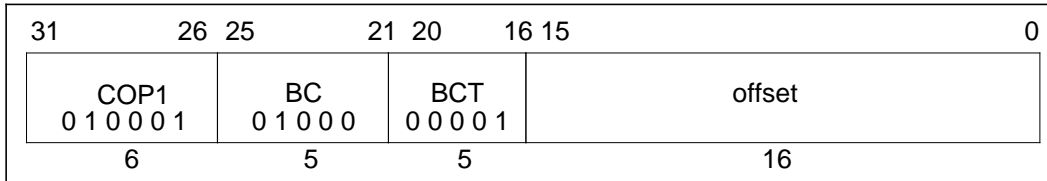
**Format:**

BC1T offset

Description:

A branch target address is computed from the sum of the address of the instruction in the delay slot and the 16-bit *offset*, shifted left two bits and sign-extended. If the result of the last floating-point compare is true (one), the program branches to the target address, with a delay of one instruction.

There must be at least one instruction between C.cond.fmt and BC1T.

Operation:

32	T-1: condition \leftarrow COC[1] T: target \leftarrow (offset ₁₅) ¹⁴ offset 0 ² T+1: if condition then PC \leftarrow PC + target endif
64	T-1: condition \leftarrow COC[1] T: target \leftarrow (offset ₁₅) ⁴⁶ offset 0 ² T+1: if condition then PC \leftarrow PC + target endif

Exceptions:

Coprocessor unusable exception

BC1TL Branch On FPU True Likely BC1TL

(Coprocessor 1)

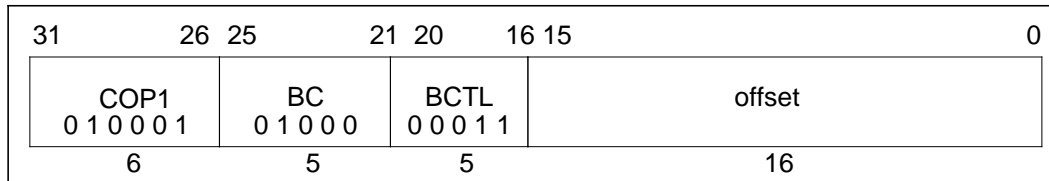
**Format:**

BC1TL offset

Description:

A branch target address is computed from the sum of the address of the instruction in the delay slot and the 16-bit *offset*, shifted left two bits and sign-extended. If the result of the last floating-point compare is true (one), the program branches to the target address, with a delay of one instruction. If the conditional branch is not taken, the instruction in the branch delay slot is nullified.

There must be at least one instruction between C.cond.fmt and BC1TL.

Operation:

32	T-1: condition \leftarrow COC[1]
	T: target \leftarrow (offset ₁₅) ¹⁴ offset 0 ²
	T+1: if condition then
	PC \leftarrow PC + target
	else
	NullifyCurrentInstruction
	endif
64	T-1: condition \leftarrow COC[1]
	T: target \leftarrow (offset ₁₅) ⁴⁶ offset 0 ²
	T+1: if condition then
	PC \leftarrow PC + target
	else
	NullifyCurrentInstruction
	endif

Exceptions:

Coprocessor unusable exception

C.cond.fmt Floating-Point Compare C.cond.fmt

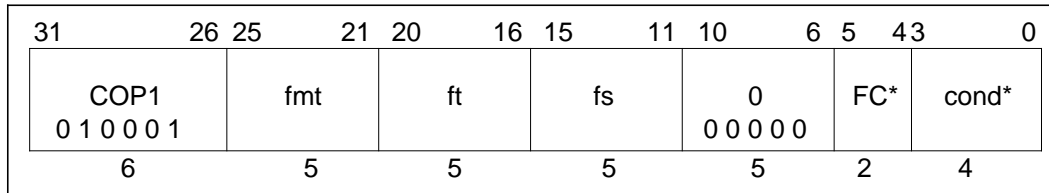
**Format:**

C.cond.fmt fs, ft

Description:

The contents of the floating-point registers specified by *fs* and *ft* are interpreted in the specified format, *fmt*, and arithmetically compared.

A result is determined based on the comparison and the conditions specified in the *cond* field. If one of the values is a Not a Number (NaN), and the high-order bit of the *cond* field is set, an invalid operation exception is taken. After a one-instruction delay, the condition is available for testing with branch on floating-point coprocessor condition instructions. There must be at least one instruction between the compare and the branch.

Comparisons are exact and can neither overflow nor underflow. Four mutually-exclusive relations are possible results: less than, equal, greater than, and unordered. The last case arises when one or both of the operands are NaN; every NaN compares unordered with everything, including itself.

Comparisons ignore the sign of zero, so $+0 = -0$.

This instruction is valid only for single- and double-precision floating-point formats. The operation is not defined if bit 0 of any register specification is set and the *FR* bit in the *Status* register equals zero, since the register numbers specify an even-odd pair of adjacent coprocessor general registers. When the *FR* bit in the *Status* register equals one, both even and odd register numbers are valid.

*See "FPU Instruction Opcode Bit Encoding" at the end of Appendix B.

C.cond.fmt**Floating-Point
Compare
(continued)****C.cond.fmt****Operation:**

```
T:   if NaN(ValueFPR(fs, fmt)) or NaN(ValueFPR(ft, fmt)) then
      less ← false
      equal ← false
      unordered ← true
      if cond3 then
        signal InvalidOperationException
      endif
    else
      less ← ValueFPR(fs, fmt) < ValueFPR(ft, fmt)
      equal ← ValueFPR(fs, fmt) = ValueFPR(ft, fmt)
      unordered ← false
    endif
    condition ← (cond2 and less) or (cond1 and equal) or
                (cond0 and unordered)
    FCR[31]23 ← condition
    COC[1] ← condition
```

Exceptions:

Coprocessor unusable
Floating-Point exception

Coprocessor Exceptions:

Unimplemented operation exception
Invalid operation exception

CEIL.L.fmt Floating-Point Ceiling to Long Fixed-Point Format CEIL.L.fmt

31	26	25	21	20	16	15	11	10	6	5	0
COP1 0 1 0 0 0 1		fmt	0 0 0 0 0 0		fs	fd		CEIL.L 0 0 1 0 1 0			
6		5	5		5	5		6			

Format:

CEIL.L.fmt fd, fs

Description:

The contents of the floating-point register specified by *fs* are interpreted in the specified source format, *fmt*, and arithmetically converted to the long fixed-point format. The result is placed in the floating-point register specified by *fd*.

Regardless of the setting of the current rounding mode, the conversion is rounded as if the current rounding mode is round to $+\infty$ (2).

This instruction is valid only for conversion from single- or double-precision floating-point formats. When the *FR* bit in the *Status* register equals one, both even and odd register numbers are valid.

When the source operand is an Infinity, NaN, or the correctly rounded integer result is outside of -2^{63} to $2^{63}-1$, the Invalid operation exception is raised. If the Invalid operation is not enabled then no exception is taken and $2^{63}-1$ is returned.

CEIL.L.fmt

**Floating-Point
Ceiling to Long
Fixed-Point Format
(continued)**

CEIL.L.fmt

Operation:

T: StoreFPR(fd, L, ConvertFmt(ValueFPR(fs, fmt), fmt, L))

Exceptions:

- Coprocessor unusable exception
- Floating-Point exception

Coprocessor Exceptions:

- Invalid operation exception
- Unimplemented operation exception
- Inexact exception
- Overflow exception

CEIL.W.fmt Floating-Point Ceiling to Single Fixed-Point Format CEIL.W.fmt

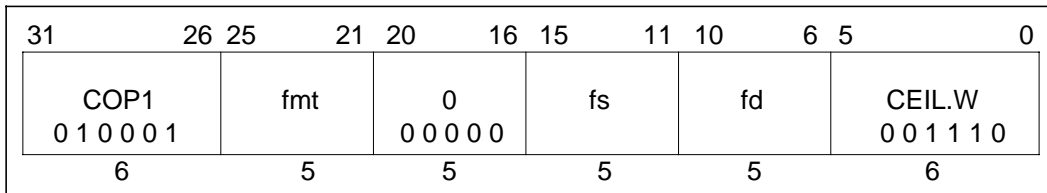
**Format:**

CEIL.W.fmt fd, fs

Description:

The contents of the floating-point register specified by *fs* are interpreted in the specified source format, *fmt*, and arithmetically converted to the single fixed-point format. The result is placed in the floating-point register specified by *fd*.

Regardless of the setting of the current rounding mode, the conversion is rounded as if the current rounding mode is round to $+\infty$ (2).

This instruction is valid only for conversion from a single- or double-precision floating-point formats. The operation is not defined if bit 0 of any register specification is set and the *FR* bit in the *Status* register equals zero, since the register numbers specify an even-odd pair of adjacent coprocessor general registers. When the *FR* bit in the *Status* register equals one, both even and odd register numbers are valid.

When the source operand is an Infinity or NaN, or the correctly rounded integer result is outside of -2^{31} to $2^{31}-1$, the Invalid operation exception is raised. If the Invalid operation is not enabled then no exception is taken and $2^{31}-1$ is returned.

CEIL.W.fmt **Floating-Point
Ceiling to Single
Fixed-Point Format
(continued)** **CEIL.W.fmt**

Operation:

T: StoreFPR(fd, W, ConvertFmt(ValueFPR(fs, fmt), fmt, W))
--

Exceptions:

- Coprocessor unusable exception
- Floating-Point exception

Coprocessor Exceptions:

- Invalid operation exception
- Unimplemented operation exception
- Inexact exception
- Overflow exception

CFC1 Move Control Word From FPU CFC1

(Coprocessor 1)

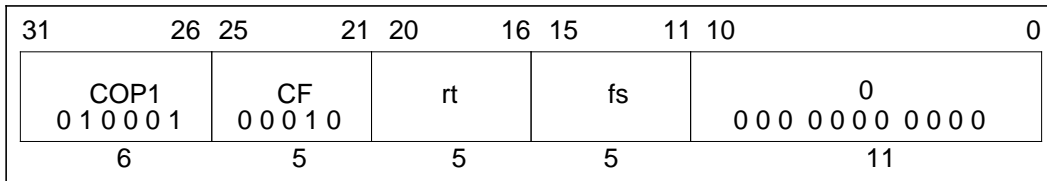
**Format:**CFC1 *rt*, *fs***Description:**

The contents of the FPU control register *fs* are loaded into general register *rt*.

This operation is only defined when *fs* equals 0 or 31.

The contents of general register *rt* are undefined for the instruction immediately following CFC1.

Operation:

32	T: temp ← FCR[<i>fs</i>] T+1: GPR[<i>rt</i>] ← temp
64	T: temp ← FCR[<i>fs</i>] T+1: GPR[<i>rt</i>] ← (temp ₃₁) ³² temp

Exceptions:

Coprocessor unusable exception

CTC1 Move Control Word To FPU CTC1

(Coprocessor 1)

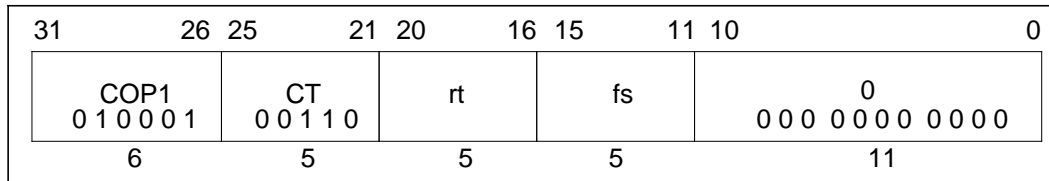
**Format:**

CTC1 rt, fs

Description:

The contents of general register *rt* are loaded into FPU control register *fs*. This operation is only defined when *fs* equals 0 or 31.

Writing to *Control Register 31*, the floating-point *Control/Status* register, causes an interrupt or exception if any cause bit and its corresponding enable bit are both set. The register will be written before the exception occurs. The contents of floating-point control register *fs* are undefined for the instruction immediately following CTC1.

Operation:

32	T:	temp ← GPR[rt]
	T+1:	FCR[fs] ← temp
		COC[1] ← FCR[31] ₂₃
64	T:	temp ← GPR[rt] _{31...0}
	T+1:	FCR[fs] ← temp
		COC[1] ← FCR[31] ₂₃

Exceptions:

Coprocessor unusable exception

Floating-Point exception

Coprocessor Exceptions:

Unimplemented operation exception

Invalid operation exception

Division by zero exception

Inexact exception

Overflow exception

Underflow exception

CVT.D.fmt Floating-Point CVT.D.fmt

Convert to Double Floating-Point Format

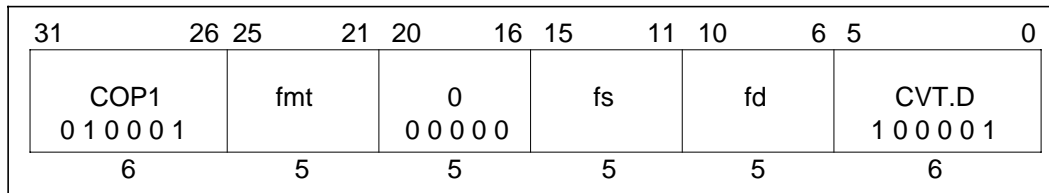
**Format:**

CVT.D.fmt fd, fs

Description:

The contents of the floating-point register specified by *fs* is interpreted in the specified source format, *fmt*, and arithmetically converted to the double binary floating-point format. The result is placed in the floating-point register specified by *fd*.

This instruction is valid only for conversions from single floating-point format, 32-bit or 64-bit fixed-point format.

If the single floating-point or single fixed-point format is specified, the operation is exact. The operation is not defined if bit 0 of any register specification is set and the *FR* bit in the *Status* register equals zero, since the register numbers specify an even-odd pair of adjacent coprocessor general registers. When the *FR* bit in the *Status* register equals one, both even and odd register numbers are valid.

Operation:

T: StoreFPR (fd, D, ConvertFmt(ValueFPR(fs, fmt), fmt, D))

Exceptions:

- Coprocessor unusable exception
- Floating-Point exception

Coprocessor Exceptions:

- Invalid operation exception
- Unimplemented operation exception
- Inexact exception
- Overflow exception
- Underflow exception

CVT.L.fmt Floating-Point Convert to Long Fixed-Point Format CVT.L.fmt

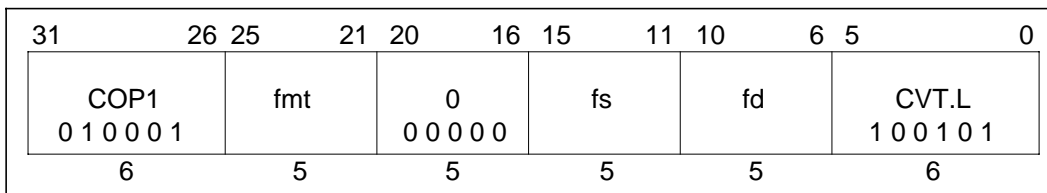
**Format:**

CVT.L.fmt fd, fs

Description:

The contents of the floating-point register specified by *fs* are interpreted in the specified source format, *fmt*, and arithmetically converted to the long fixed-point format. The result is placed in the floating-point register specified by *fd*. This instruction is valid only for conversions from single- or double-precision floating-point formats. The operation is not defined if bit 0 of any register specification is set and the *FR* bit in the *Status* register equals zero.

When the source operand is an Infinity, NaN, or the correctly rounded integer result is outside of -2^{63} to $2^{63}-1$, the Invalid operation exception is raised. If the Invalid operation is not enabled then no exception is taken and $2^{63}-1$ is returned.

Operation:

T: StoreFPR (fd, L, ConvertFmt(ValueFPR(fs, fmt), fmt, L))

Exceptions:

- Coprocessor unusable exception
- Floating-Point exception

Coprocessor Exceptions:

- Invalid operation exception
- Unimplemented operation exception
- Inexact exception
- Overflow exception

CVT.S.fmt Floating-Point Convert to Single Floating-Point Format CVT.S.fmt

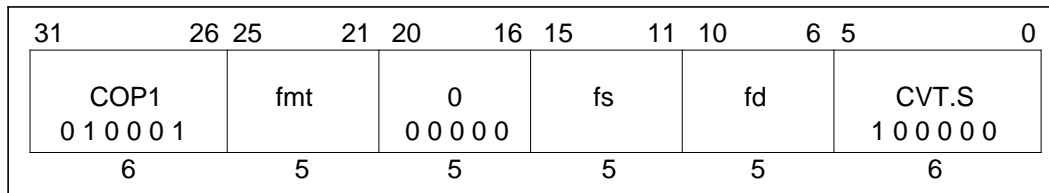
**Format:**

CVT.S.fmt fd, fs

Description:

The contents of the floating-point register specified by *fs* are interpreted in the specified source format, *fmt*, and arithmetically converted to the single binary floating-point format. The result is placed in the floating-point register specified by *fd*. Rounding occurs according to the currently specified rounding mode.

This instruction is valid only for conversions from double floating-point format, or from 32-bit or 64-bit fixed-point format. The operation is not defined if bit 0 of any register specification is set and the *FR* bit in the *Status* register equals zero, since the register numbers specify an even-odd pair of adjacent coprocessor general registers. When the *FR* bit in the *Status* register equals one, both even and odd register numbers are valid.

Operation:

T: StoreFPR(fd, S, ConvertFmt(ValueFPR(fs, fmt), fmt, S))
--

Exceptions:

- Coprocessor unusable exception
- Floating-Point exception

Coprocessor Exceptions:

- Invalid operation exception
- Unimplemented operation exception
- Inexact exception
- Overflow exception
- Underflow exception

CVT.W.fmt Floating-Point CVT.W.fmt

Convert to Fixed-Point Format

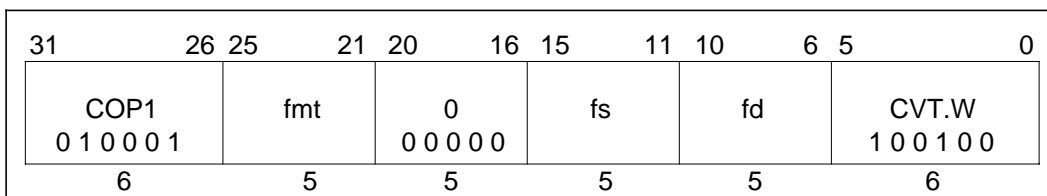
**Format:**

CVT.W.fmt fd, fs

Description:

The contents of the floating-point register specified by *fs* are interpreted in the specified source format, *fmt*, and arithmetically converted to the single fixed-point format. The result is placed in the floating-point register specified by *fd*. This instruction is valid only for conversion from a single- or double-precision floating-point formats. The operation is not defined if bit 0 of any register specification is set and the *FR* bit in the *Status* register equals zero, since the register numbers specify an even-odd pair of adjacent coprocessor general registers. When the *FR* bit in the *Status* register equals one, both even and odd register numbers are valid.

When the source operand is an Infinity or NaN, or the correctly rounded integer result is outside of -2^{31} to $2^{31}-1$, an Invalid operation exception is raised. If Invalid operation is not enabled, then no exception is taken and $2^{31}-1$ is returned.

Operation:

T: StoreFPR(fd, W, ConvertFmt(ValueFPR(fs, fmt), fmt, W))
--

Exceptions:

- Coprocessor unusable exception
- Floating-Point exception

Coprocessor Exceptions:

- Invalid operation exception
- Unimplemented operation exception
- Inexact exception
- Overflow exception

DIV.fmt Floating-Point Divide DIV.fmt

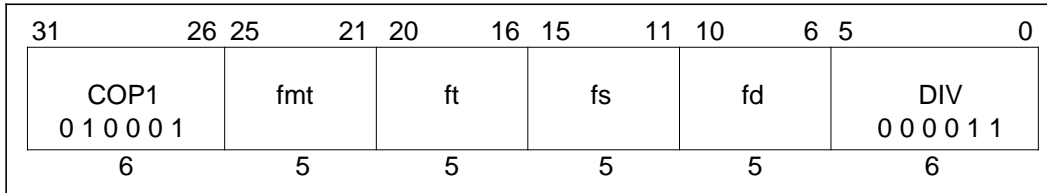
**Format:**

DIV.fmt fd, fs, ft

Description:

The contents of the floating-point registers specified by *fs* and *ft* are interpreted in the specified *format* and the value in the *fs* field is divided by the value in the *ft* field. The result is rounded as if calculated to infinite precision and then rounded to the specified format, according to the current rounding mode. The result is placed in the floating-point register specified by *fd*.

This instruction is valid for only single or double precision floating-point formats.

The operation is not defined if bit 0 of any register specification is set and the *FR* bit in the *Status* register equals zero, since the register numbers specify an even-odd pair of adjacent coprocessor general registers. When the *FR* bit in the *Status* register equals one, both even and odd register numbers are valid.

Operation:

T: StoreFPR (fd, fmt, ValueFPR(fs, fmt)/ValueFPR(ft, fmt))

Exceptions:

Coprocessor unusable exception
Floating-Point exception

Coprocessor Exceptions:

Unimplemented operation exception	Invalid operation exception
Division-by-zero exception	Inexact exception
Overflow exception	Underflow exception

DMFC1 Doubleword Move From Floating-Point Coprocessor DMFC1

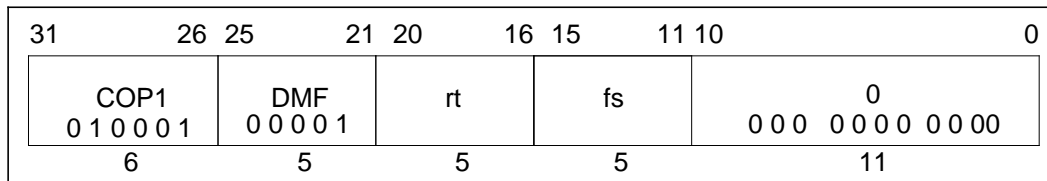
**Format:**DMFC1 *rt*, *fs***Description:**

The contents of register *fs* from the floating-point coprocessor is stored into processor register *rt*.

The contents of general register *rt* are undefined for the instruction immediately following DMFC1.

The *FR* bit in the *Status* register specifies whether all 32 registers of the R4000 are addressable. When *FR* equals zero, this instruction is not defined when the least significant bit of *fs* is non-zero. When *FR* is set, *fs* may specify either odd or even registers.

Operation:

```

64   T:   if SR26 = 1 then /* 64-bit wide FGRs */
        data ← FGR[fs]
        elseif fs0 = 0 then /* valid specifier, 32-bit wide FGRs */
        data ← FGR[fs+1] || FGR[fs]
        else /* undefined for odd 32-bit reg #s */
        data ← undefined64
        endif
T+1: GPR[rt] ← data

```

Exceptions:

Coprocessor unusable exception

Coprocessor Exceptions:

Unimplemented operation exception

DMTC1 Doubleword Move To Floating-Point Coprocessor DMTC1

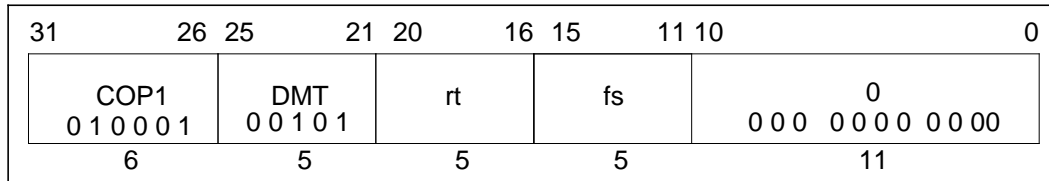
**Format:**

DMTC1 rt, fs

Description:

The contents of general register *rt* are loaded into coprocessor register *fs* of the CP1.

The contents of floating-point register *fs* are undefined for the instruction immediately following DMTC1.

The *FR* bit in the *Status* register specifies whether all 32 registers of the R4000 are addressable. When *FR* equals zero, this instruction is not defined when the least significant bit of *fs* is non-zero. When *FR* equals one, *fs* may specify either odd or even registers.

Operation:

```

64   T:   data ← GPR[rt]
      T+1: if SR26 = 1 then /* 64-bit wide FGRs */
          FGR[fs] ← data
        elseif fs0 = 0 then /* valid specifier, 32-bit wide valid FGRs */
          FGR[fs+1] ← data63...32
          FGR[fs] ← data31...0
        else /* undefined result for odd 32-bit reg #s */
          undefined_result
        endif

```

Exceptions:

Coprocessor unusable exception

Coprocessor Exceptions:

Unimplemented operation exception

FLOOR.L.fmt Floating-Point
Floor to Long **FLOOR.L.fmt**
Fixed-Point Format

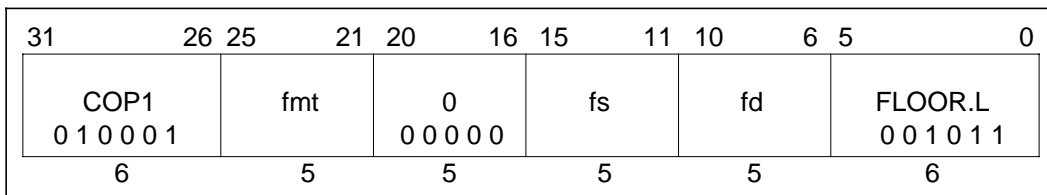
**Format:**

FLOOR.L.fmt fd, fs

Description:

The contents of the floating-point register specified by *fs* are interpreted in the specified source format, *fmt*, and arithmetically converted to the long fixed-point format. The result is placed in the floating-point register specified by *fd*.

Regardless of the setting of the current rounding mode, the conversion is rounded as if the current rounding mode is round to $-\infty$ (3).

This instruction is valid only for conversion from single- or double-precision floating-point formats.

When the source operand is an Infinity, NaN, or the correctly rounded integer result is outside of -2^{63} to $2^{63}-1$, the Invalid operation exception is raised. If the Invalid operation is not enabled then no exception is taken and $2^{63}-1$ is returned.

FLOOR.L.fmt **Floating-Point**
 Floor to Long
 Fixed-Point Format
 (continued) **FLOOR.L.fmt**

Operation:

T: StoreFPR(fd, L, ConvertFmt(ValueFPR(fs, fmt), fmt, L))
--

Exceptions:

- Coprocessor unusable exception
- Floating-Point exception

Coprocessor Exceptions:

- Invalid operation exception
- Unimplemented operation exception
- Inexact exception
- Overflow exception

FLOOR.W.fmt Floating-Point FLOOR.W.fmt

Floor to Single Fixed-Point Format

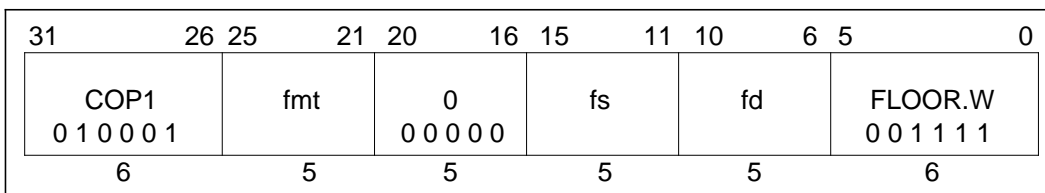
**Format:**

FLOOR.W.fmt fd, fs

Description:

The contents of the floating-point register specified by *fs* are interpreted in the specified source format, *fmt*, and arithmetically converted to the single fixed-point format. The result is placed in the floating-point register specified by *fd*.

Regardless of the setting of the current rounding mode, the conversion is rounded as if the current rounding mode is round to $-\infty$ ($RM = 3$).

This instruction is valid only for conversion from a single- or double-precision floating-point formats. The operation is not defined if bit 0 of any register specification is set and the *FR* bit in the *Status* register equals zero, since the register numbers specify an even-odd pair of adjacent coprocessor general registers. When the *FR* bit in the *Status* register equals one, both even and odd register numbers are valid.

When the source operand is an Infinity or NaN, or the correctly rounded integer result is outside of -2^{31} to $2^{31}-1$, an Invalid operation exception is raised. If Invalid operation is not enabled, then no exception is taken and $2^{31}-1$ is returned.

FLOOR.W.fmt Floating-Point
Floor to Single **FLOOR.W.fmt**
Fixed-Point Format
(continued)

Operation:

T: StoreFPR(fd, W, ConvertFmt(ValueFPR(fs, fmt), fmt, W))
--

Exceptions:

Coprocessor unusable exception
Floating-Point exception

Coprocessor Exceptions:

Invalid operation exception
Unimplemented operation exception
Inexact exception
Overflow exception

LDC1 Load Doubleword to FPU (Coprocessor 1) LDC1

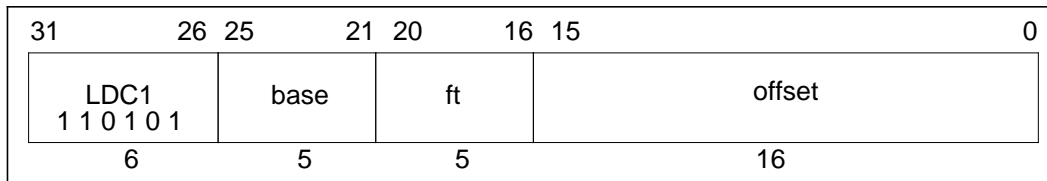
**Format:**

LDC1 ft, offset(base)

Description:

The 16-bit *offset* is sign-extended and added to the contents of general register *base* to form an unsigned effective address.

In 32-bit mode, the contents of the doubleword at the memory location specified by the effective address is loaded into registers *ft* and *ft+1* of the floating-point coprocessor. This instruction is not valid, and is undefined, when the least significant bit of *ft* is non-zero.

In 64-bit mode, the contents of the doubleword at the memory location specified by the effective address are loaded into the 64-bit register *ft* of the floating point coprocessor.

The *FR* bit of the *Status* register (SR_{26}) specifies whether all 32 registers of the R4000 are addressable. If *FR* equals zero, this instruction is not defined when the least significant bit of *ft* is non-zero. If *FR* equals one, *ft* may specify either odd or even registers.

If any of the three least-significant bits of the effective address are non-zero, an address error exception takes place.

LDC1

**Load Doubleword to FPU
(Coprocessor 1)
(continued)**

LDC1**Operation:**

32	T:	$vAddr \leftarrow ((offset_{15})^{16} \parallel offset_{15..0}) + GPR[base]$
64	T:	$vAddr \leftarrow ((offset_{15})^{48} \parallel offset_{15..0}) + GPR[base]$
32, 64		<pre> (pAddr, uncached) ← AddressTranslation (vAddr, DATA) data ← LoadMemory(uncached, DOUBLEWORD, pAddr, vAddr, DATA) if SR₂₆ = 1 then /* 64-bit wide FGRs */ FGR[ft] ← data elseif ft₀ = 0 then /* valid specifier, 32-bit wide FGRs */ FGR[ft+1] ← data_{63...32} FGR[ft] ← data_{31...0} else /* undefined result if odd */ undefined_result endif </pre>

Exceptions:

- Coprocessor unusable
- TLB refill exception
- TLB invalid exception
- Bus error exception
- Address error exception

LWC1

**Load Word to FPU
(Coprocessor 1)
(continued)**

LWC1**Operation:**

```

32   T:   vAddr ← ((offset15)16 || offset15...0) + GPR[base]
64   T:   vAddr ← ((offset15)48 || offset15...0) + GPR[base]

32, 64   (pAddr, uncached) ← AddressTranslation (vAddr, DATA)
          pAddr ← pAddrPSIZE-1...3 || (pAddr2...0 xor (ReverseEndian || 02))
          mem ← LoadMemory(uncached, WORD, pAddr, vAddr, DATA)
          byte ← vAddr2...0 xor (BigEndianCPU || 02)
          /* "mem" is aligned 64-bits from memory. Pick out correct bytes. */
          if SR26 = 1 then /* 64-bit wide FGRs */
              FGR[ft] ← undefined32 || mem31+8*byte...8*byte
          else /* 32-bit wide FGRs */
              FGR[ft] ← mem31+8*byte...8*byte
          endif

```

Exceptions:

- Coprocessor unusable
- TLB refill exception
- TLB invalid exception
- Bus error exception
- Address error exception

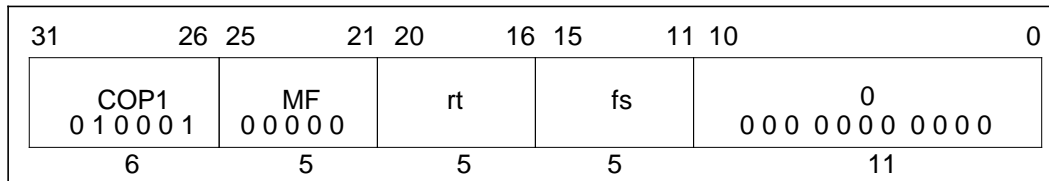
MFC1**Move From FPU
(Coprocessor 1)****MFC1****Format:**MFC1 *rt*, *fs***Description:**

The contents of register *fs* from the floating-point coprocessor are stored into processor register *rt*.

The contents of register *rt* are undefined for the instruction immediately following MFC1.

The *FR* bit of the *Status* register specifies whether all 32 registers of the R4000 are addressable. If *FR* equals zero, MFC1 stores either the high or low half of the 16 even *Floating-Point* registers. If *FR* equals one, MFC1 stores the low 32-bits of both even and odd *Floating-Point* registers.

Operation:

32	T: data ← FGR[<i>fs</i>] _{31...0}
	T+1: GPR[<i>rt</i>] ← data
64	T: data ← FGR[<i>fs</i>] _{31...0}
	T+1: GPR[<i>rt</i>] ← (data ₃₁) ³² data

Exceptions:

Coprocessor unusable exception

MOV.fmt Floating-Point Move MOV.fmt

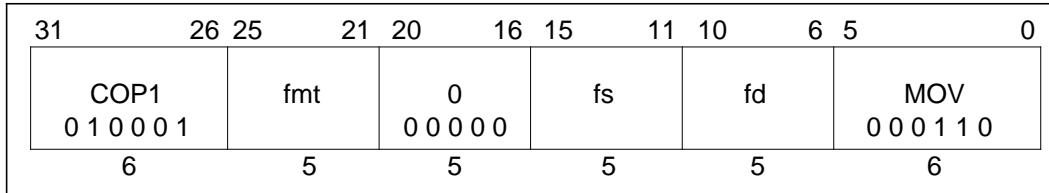
**Format:**MOV.fmt *fd*, *fs***Description:**

The contents of the FPU register specified by *fs* are interpreted in the specified *format* and are copied into the FPU register specified by *fd*.

The move operation is non-arithmetic; no IEEE 754 exceptions occur as a result of the instruction.

This instruction is valid only for single- or double-precision floating-point formats.

The operation is not defined if bit 0 of any register specification is set and the *FR* bit in the *Status* register equals zero, since the register numbers specify an even-odd pair of adjacent coprocessor general registers. When the *FR* bit in the *Status* register equals one, both even and odd register numbers are valid.

Operation:

T: StoreFPR(<i>fd</i> , <i>fmt</i> , ValueFPR(<i>fs</i> , <i>fmt</i>))
--

Exceptions:

- Coprocessor unusable exception
- Floating-Point exception

Coprocessor Exceptions:

- Unimplemented operation exception

MTC1 Move To FPU (Coprocessor 1) MTC1

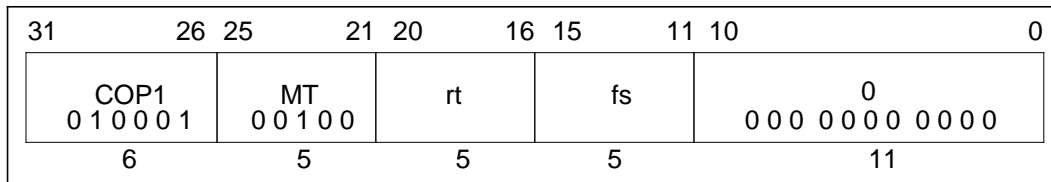
**Format:**

MTC1 rt, fs

Description:

The contents of register *rt* are loaded into the FPU general register at location *fs*.

The contents of floating-point register *fs* is undefined for the instruction immediately following MTC1.

The *FR* bit of the *Status* register specifies whether all 32 registers of the R4000 are addressable. If *FR* equals zero, MTC1 loads either the high or low half of the 16 even *Floating-Point* registers. If *FR* equals one, MTC1 loads the low 32-bits of both even and odd *Floating-Point* registers.

Operation:

```

32,64 T:  data ← GPR[rt]31..0
      T+1: if SR26 = 1 then /* 64-bit wide FGRs */
           FGR[fs] ← undefined32 || data
           else /* 32-bit wide FGRs */
           FGR[fs] ← data
           endif

```

Exceptions:

Coprocessor unusable exception

MUL.fmt Floating-Point Multiply MUL.fmt

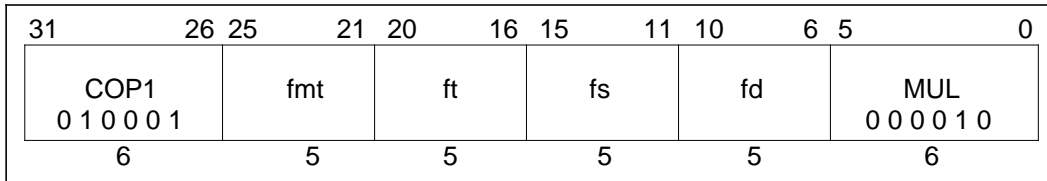
**Format:**

MUL.fmt fd, fs, ft

Description:

The contents of the floating-point registers specified by *fs* and *ft* are interpreted in the specified *format* and arithmetically multiplied. The result is rounded as if calculated to infinite precision and then rounded to the specified *format*, according to the current rounding mode. The result is placed in the floating-point register specified by *fd*.

This instruction is valid only for single- or double-precision floating-point formats.

The operation is not defined if bit 0 of any register specification is set and the *FR* bit in the *Status* register equals zero, since the register numbers specify an even-odd pair of adjacent coprocessor general registers. When the *FR* bit in the *Status* register equals one, both even and odd register numbers are valid.

Operation:

T: StoreFPR (fd, fmt, ValueFPR(fs, fmt) * ValueFPR(ft, fmt))

Exceptions:

- Coprocessor unusable exception
- Floating-Point exception

Coprocessor Exceptions:

- Unimplemented operation exception
- Invalid operation exception
- Inexact exception
- Overflow exception
- Underflow exception

NEG.fmt Floating-Point Negate NEG.fmt

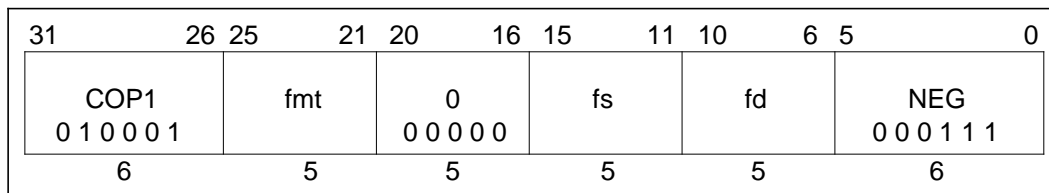
**Format:**NEG.fmt *fd*, *fs***Description:**

The contents of the FPU register specified by *fs* are interpreted in the specified *format* and the arithmetic negation is taken (polarity of the sign-bit is changed). The result is placed in the FPU register specified by *fd*.

The negate operation is arithmetic; an NaN operand signals invalid operation.

This instruction is valid only for single- or double-precision floating-point formats. The operation is not defined if bit 0 of any register specification is set and the *FR* bit in the *Status* register equals zero, since the register numbers specify an even-odd pair of adjacent coprocessor general registers. When the *FR* bit in the *Status* register equals one, both even and odd register numbers are valid.

Operation:

T: StoreFPR(<i>fd</i> , <i>fmt</i> , Negate(ValueFPR(<i>fs</i> , <i>fmt</i>)))
--

Exceptions:

- Coprocessor unusable exception
- Floating-Point exception

Coprocessor Exceptions:

- Unimplemented operation exception
- Invalid operation exception

ROUND.L.fmt Floating-Point **ROUND.L.fmt**
 Round to Long
 Fixed-Point Format

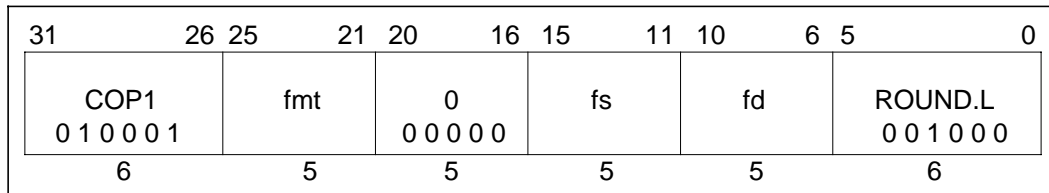
**Format:**

ROUND.L.fmt fd, fs

Description:

The contents of the floating-point register specified by *fs* are interpreted in the specified source format, *fmt*, and arithmetically converted to the long fixed-point format. The result is placed in the floating-point register specified by *fd*.

Regardless of the setting of the current rounding mode, the conversion is rounded as if the current rounding mode is round to nearest/even (0).

This instruction is valid only for conversion from single- or double-precision floating-point formats.

When the source operand is an Infinity, NaN, or the correctly rounded integer result is outside of -2^{63} to $2^{63} - 1$, the Invalid operation exception is raised. If the Invalid operation is not enabled then no exception is taken and $2^{63} - 1$ is returned.

ROUND.L.fmt Floating-Point
 Round to Long
ROUND.L.fmt Fixed-Point Format
 (continued)

Operation:

T: StoreFPR(fd, L, ConvertFmt(ValueFPR(fs, fmt), fmt, L))
--

Exceptions:

- Coprocessor unusable exception
- Floating-Point exception

Coprocessor Exceptions:

- Invalid operation exception
- Unimplemented operation exception
- Inexact exception
- Overflow exception

ROUND.W.fmt Floating-Point ROUND.W.fmt

Round to Single Fixed-Point Format

31	26	25	21	20	16	15	11	10	6	5	0
COP1 0 1 0 0 0 1		fmt		0 0 0 0 0 0		fs		fd		ROUND.W 0 0 1 1 0 0	
6		5		5		5		5		6	

Format:

ROUND.W.fmt fd, fs

Description:

The contents of the floating-point register specified by *fs* are interpreted in the specified source format, *fmt*, and arithmetically converted to the single fixed-point format. The result is placed in the floating-point register specified by *fd*.

Regardless of the setting of the current rounding mode, the conversion is rounded as if the current rounding mode is round to the nearest/even (RM = 0).

This instruction is valid only for conversion from a single- or double-precision floating-point formats. The operation is not defined if bit 0 of any register specification is set and the *FR* bit in the *Status* register equals zero, since the register numbers specify an even-odd pair of adjacent coprocessor general registers. When the *FR* bit in the *Status* register equals one, both even and odd register numbers are valid.

When the source operand is an Infinity or NaN, or the correctly rounded integer result is outside of -2^{31} to $2^{31} - 1$, an Invalid operation exception is raised. If Invalid operation is not enabled, then no exception is taken and $2^{31} - 1$ is returned.

ROUND.W.fmt Floating-Point **ROUND.W.fmt**
Round to Single
Fixed-Point Format
(continued)

Operation:

T: StoreFPR(fd, W, ConvertFmt(ValueFPR(fs, fmt), fmt, W))

Exceptions:

- Coprocessor unusable exception
- Floating-Point exception

Coprocessor Exceptions:

- Invalid operation exception
- Unimplemented operation exception
- Inexact exception
- Overflow exception

SDC1 Store Doubleword from FPU (Coprocessor 1) SDC1

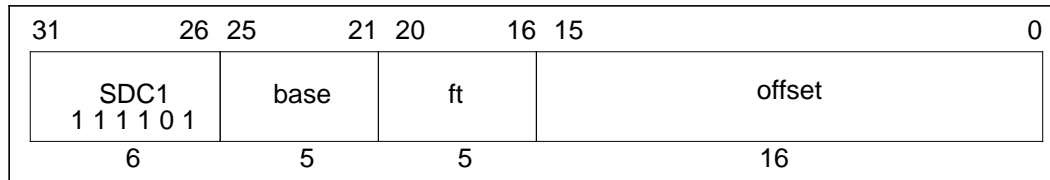
**Format:**

SDC1 ft, offset(base)

Description:

The 16-bit *offset* is sign-extended and added to the contents of general register *base* to form an unsigned effective address.

In 32-bit mode, the contents of registers *ft* and *ft+1* from the floating-point coprocessor are stored at the memory location specified by the effective address. This instruction is not valid, and is undefined, when the least significant bit of *ft* is non-zero.

In 64-bit mode, the 64-bit register *ft* is stored to the contents of the doubleword at the memory location specified by the effective address. The *FR* bit of the *Status* register (SR_{26}) specifies whether all 32 registers of the R4000 are addressable. When *FR* equals zero, this instruction is not defined if the least significant bit of *ft* is non-zero. If *FR* equals one, *ft* may specify either odd or even registers.

If any of the three least-significant bits of the effective address are non-zero, an address error exception takes place.

SDC1

**Store Doubleword from FPU
(Coprocessor 1)
(continued)**

SDC1**Operation:**

32	T:	$vAddr \leftarrow (\text{offset}_{15})^{16} \parallel \text{offset}_{15\dots 0} + \text{GPR}[\text{base}]$
64	T:	$vAddr \leftarrow (\text{offset}_{15})^{48} \parallel \text{offset}_{15\dots 0} + \text{GPR}[\text{base}]$
32,64		<p>$(pAddr, \text{uncached}) \leftarrow \text{AddressTranslation}(vAddr, \text{DATA})$ if $SR_{26} = 1$ /* 64-bit wide FGRs */ $data \leftarrow \text{FGR}[\text{ft}]$ elseif $ft_0 = 0$ then /* valid specifier, 32-bit wide FGRs */ $data \leftarrow \text{FGR}[\text{ft}+1] \parallel \text{FGR}[\text{ft}]$ else /* undefined for odd 32-bit reg #s */ $data \leftarrow \text{undefined}^{64}$ endif StoreMemory(uncached, DOUBLEWORD, data, pAddr, vAddr, DATA)</p>

Exceptions:

- Coprocessor unusable
- TLB refill exception
- TLB invalid exception
- TLB modification exception
- Bus error exception
- Address error exception

SQRT.fmt Floating-Point Square Root SQRT.fmt

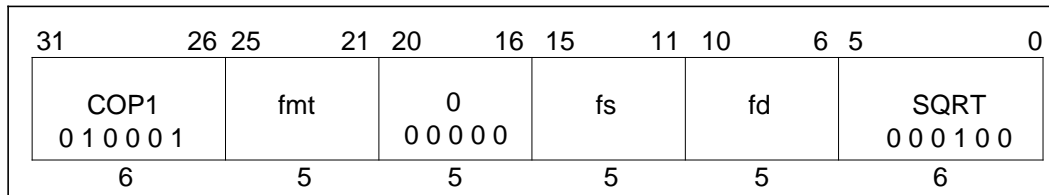
**Format:**

SQRT.fmt fd, fs

Description:

The contents of the floating-point register specified by *fs* are interpreted in the specified *format* and the positive arithmetic square root is taken. The result is rounded as if calculated to infinite precision and then rounded to the specified *format*, according to the current rounding mode. If the value of *fs* corresponds to -0 , the result will be -0 . The result is placed in the floating-point register specified by *fd*.

This instruction is valid only for single- or double-precision floating-point formats.

The operation is not defined if bit 0 of any register specification is set and the *FR* bit in the *Status* register equals zero, since the register numbers specify an even-odd pair of adjacent coprocessor general registers. When the *FR* bit in the *Status* register equals one, both even and odd register numbers are valid.

Operation:

T: StoreFPR(fd, fmt, SquareRoot(ValueFPR(fs, fmt)))
--

Exceptions:

- Coprocessor unusable exception
- Floating-Point exception

Coprocessor Exceptions:

- Unimplemented operation exception
- Invalid operation exception
- Inexact exception

SUB.fmt Floating-Point Subtract SUB.fmt

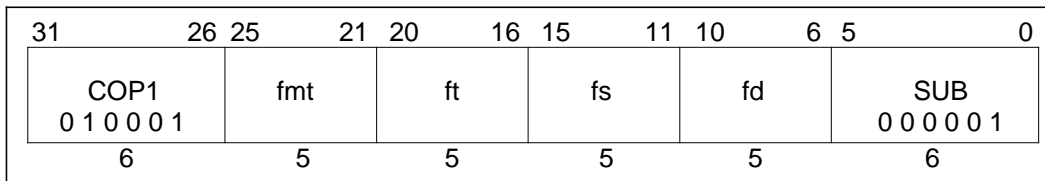
**Format:**

SUB.fmt fd, fs, ft

Description:

The contents of the floating-point registers specified by *fs* and *ft* are interpreted in the specified *format* and the value in the *ft* field is subtracted from the value in the *fs* field. The result is rounded as if calculated to infinite precision and then rounded to the specified *format*, according to the current rounding mode. The result is placed in the floating-point register specified by *fd*. This instruction is valid only for single- or double-precision floating-point formats.

The operation is not defined if bit 0 of any register specification is set and the *FR* bit in the *Status* register equals zero, since the register numbers specify an even-odd pair of adjacent coprocessor general registers. When the *FR* bit in the *Status* register equals one, both even and odd register numbers are valid.

Operation:

T: StoreFPR (fd, fmt, ValueFPR(fs, fmt) – ValueFPR(ft, fmt))

Exceptions:

- Coprocessor unusable exception
- Floating-Point exception

Coprocessor Exceptions:

- Unimplemented operation exception
- Invalid operation exception
- Inexact exception
- Overflow exception
- Underflow exception

SWC1 Store Word from FPU (Coprocessor 1) SWC1

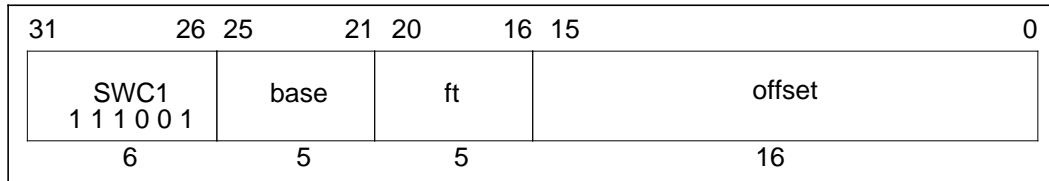
**Format:**

SWC1 ft, offset(base)

Description:

The 16-bit *offset* is sign-extended and added to the contents of general register *base* to form an unsigned effective address. The contents of register *ft* from the floating-point coprocessor are stored at the memory location specified by the effective address.

The *FR* bit of the *Status* register specifies whether all 64-bit floating-point registers are addressable.

If *FR* equals zero, SWC1 stores either the high or low half of the 16 even floating-point registers.

If *FR* equals one, SWC1 stores the low 32-bits of both even and odd floating-point registers.

If either of the two least-significant bits of the effective address are non-zero, an address error exception occurs.

SWC1

**Store Word from FPU
(Coprocessor 1)
(continued)**

SWC1**Operation:**

```

32   T:   vAddr ← ((offset15)16 || offset15...0) + GPR[base]
64   T:   vAddr ← ((offset15)48 || offset15...0) + GPR[base]

32, 64   (pAddr, uncached) ← AddressTranslation (vAddr, DATA)
          pAddr ← pAddrPSIZE-1...3 // (pAddr2...0 xor (ReverseEndian || 02))
          byte ← vAddr2...0 xor (BigEndianCPU || 02)
          /* the bytes of the word are put in the correct byte lanes in
           * "data" for a 64-bit path to memory */
          if SR26 = 1 then /* 64-bit wide FGRs */
              data ← FGR[ft]63-8*byte...0 || 08*byte
          else /* 32-bit wide FGRs */
              data ← 032-8*byte || FGR[ft] || 08*byte
          endif
          StoreMemory (uncached, WORD, data, pAddr, vAddr, DATA)

```

Exceptions:

- Coprocessor unusable
- TLB refill exception
- TLB invalid exception
- TLB modification exception
- Bus error exception
- Address error exception

TRUNC.L.fmt Floating-Point Truncate to Long Fixed-Point Format TRUNC.L.fmt

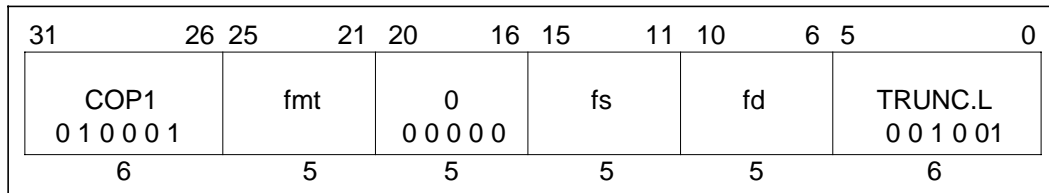
**Format:**

TRUNC.L.fmt fd, fs

Description:

The contents of the floating-point register specified by *fs* are interpreted in the specified source format, *fmt*, and arithmetically converted to the long fixed-point format. The result is placed in the floating-point register specified by *fd*.

Regardless of the setting of the current rounding mode, the conversion is rounded as if the current rounding mode is round toward zero (1).

This instruction is valid only for conversion from single- or double-precision floating-point formats.

When the source operand is an Infinity, NaN, or the correctly rounded integer result is outside of -2^{63} to $2^{63}-1$, the Invalid operation exception is raised. If the Invalid operation is not enabled then no exception is taken and $2^{63}-1$ is returned.

TRUNC.L.fmt **Floating-Point
Truncate to Long
Fixed-Point Format
(continued)** **TRUNC.L.fmt**

Operation:

T: StoreFPR(fd, L, ConvertFmt(ValueFPR(fs, fmt), fmt, L))
--

Exceptions:

- Coprocessor unusable exception
- Floating-Point exception

Coprocessor Exceptions:

- Invalid operation exception
- Unimplemented operation exception
- Inexact exception
- Overflow exception

TRUNC.W.fmt Floating-Point TRUNC.W.fmt

Truncate to Single
Fixed-Point Format

31	26 25	21 20	16 15	11 10	6 5	0
COP1 0 1 0 0 0 1	fmt	0 0 0 0 0 0	fs	fd	TRUNC.W 0 0 1 1 0 1	
6	5	5	5	5	6	

Format:

TRUNC.W.fmt fd, fs

Description:

The contents of the FPU register specified by *fs* are interpreted in the specified source format *fmt* and arithmetically converted to the single fixed-point format. The result is placed in the FPU register specified by *fd*.

Regardless of the setting of the current rounding mode, the conversion is rounded as if the current rounding mode is round toward zero ($RM = 1$).

This instruction is valid only for conversion from a single- or double-precision floating-point formats. The operation is not defined if bit 0 of any register specification is set and the *FR* bit in the *Status* register equals zero, since the register numbers specify an even-odd pair of adjacent coprocessor general registers. When the *FR* bit in the *Status* register equals one, both even and odd register numbers are valid.

When the source operand is an Infinity or NaN, or the correctly rounded integer result is outside of -2^{31} to 2^{31-1} , an Invalid operation exception is raised. If Invalid operation is not enabled, then no exception is taken and -2^{31} is returned.

TRUNC.W.fmt Floating-Point **TRUNC.W.fmt**
Truncate to Single
Fixed-Point Format
(continued)

Operation:

T: StoreFPR(fd, W, ConvertFmt(ValueFPR(fs, fmt), fmt, W))

Exceptions:

- Coprocessor unusable exception
- Floating-Point exception

Coprocessor Exceptions:

- Invalid operation exception
- Unimplemented operation exception
- Inexact exception
- Overflow exception

FPU Instruction Opcode Bit Encoding

		Opcode							
		28...26							
31...29		0	1	2	3	4	5	6	7
0									
1									
2			COP1						
3									
4									
5									
6			LWC1				LDC1		
7			SWC1				SDC1		

		sub							
		23...21							
25...24		0	1	2	3	4	5	6	7
0		MF	DMF η	CF	δ	MT	DMT η	CT	δ
1		BC	δ	δ	δ	δ	δ	δ	δ
2		S	D	δ	δ	W	L η	δ	δ
3		δ	δ	δ	δ	δ	δ	δ	δ

		br							
		18...16							
20...19		0	1	2	3	4	5	6	7
0		BCF	BCT	BCFL	BCTL	γ	γ	γ	γ
1		γ	γ	γ	γ	γ	γ	γ	γ
2		γ	γ	γ	γ	γ	γ	γ	γ
3		γ	γ	γ	γ	γ	γ	γ	γ

Figure B-3 Bit Encoding for FPU Instructions

		function							
5...3	2...0	0	1	2	3	4	5	6	7
0		ADD	SUB	MUL	DIV	SQRT	ABS	MOV	NEG
1		ROUND.L η	TRUNC.L η	CEIL.L η	FLOOR.L η	ROUND.W	TRUNC.W	CEIL.W	FLOOR.W
2		δ	δ	δ	δ	δ	δ	δ	δ
3		δ	δ	δ	δ	δ	δ	δ	δ
4		CVT.S	CVT.D	δ	δ	CVT.W	CVT.L η	δ	δ
5		δ	δ	δ	δ	δ	δ	δ	δ
6		C.F	C.UN	C.EQ	C.UEQ	C.OLT	C.ULT	C.OLE	C.ULE
7		C.SF	C.NGLE	C.SEQ	C.NGL	C.LT	C.NGE	C.LE	C.NGT

Figure B-3 (cont.) Bit Encoding for FPU Instructions

Key:

- γ Operation codes marked with a gamma cause a reserved instruction exception. They are reserved for future versions of the architecture.
- δ Operation codes marked with a delta cause unimplemented operation exceptions in all current implementations and are reserved for future versions of the architecture.
- η Operation codes marked with an eta are valid only when MIPS III instructions are enabled. Any attempt to execute these without MIPS III instructions enabled causes an unimplemented operation exception.